

RENOVA

1RSC 29-40

Performance curve for Vacuum pump

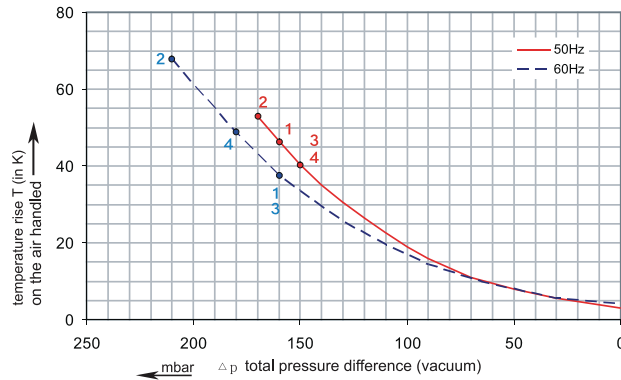
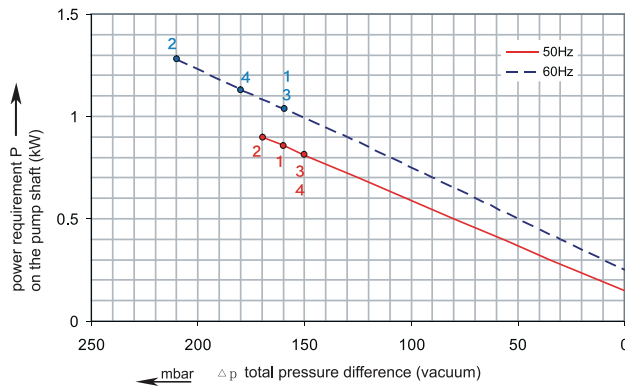
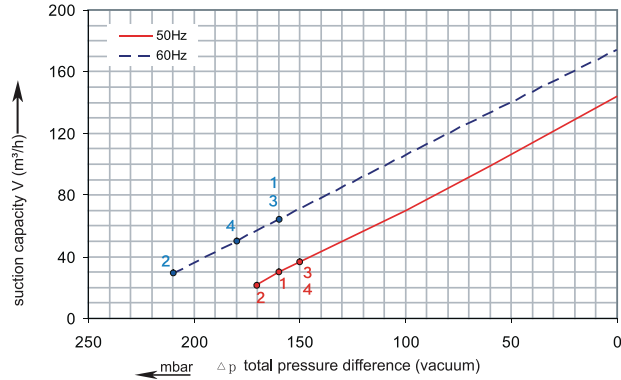

1RSC 29-40

Performance curve for Compressor

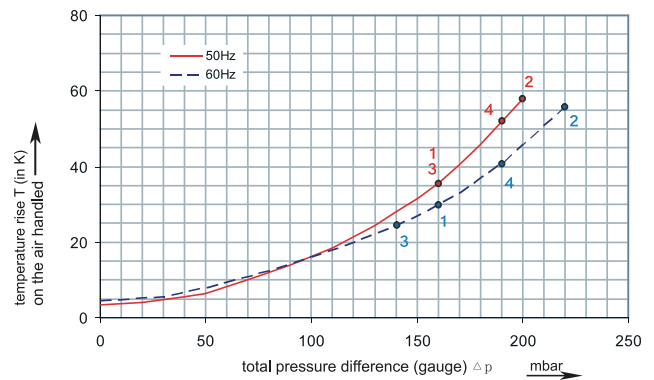
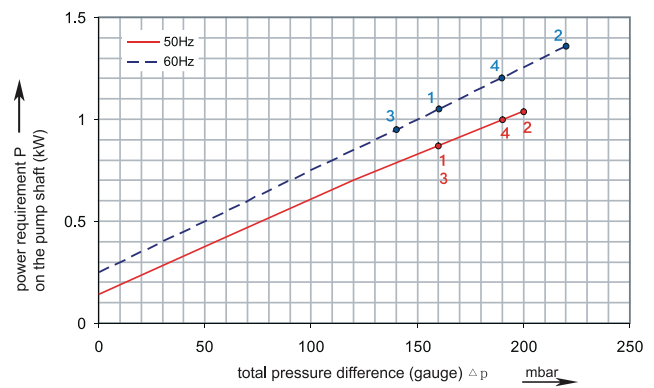
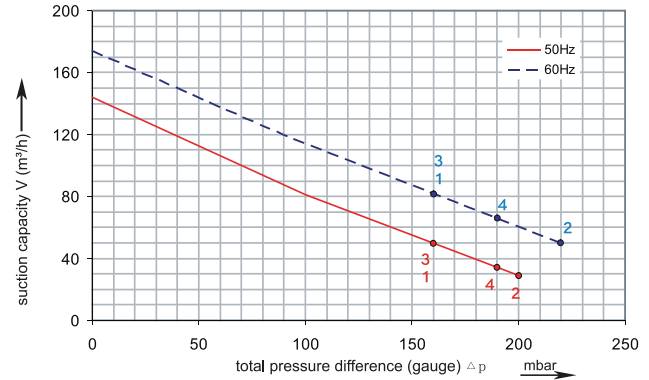

The performance curves are based on air at a temperature of 15 °C and an atmospheric pressure of 1013 mbar with a tolerance of +/- 10 %. The total pressure differences are valid for suction and ambient temperatures up to 25 °C. For other conditions please confer with us.

Each RSC type can be applied both as vacuum pump and compressor in continuous operation over the total stated performance curve range. The motors are available as standard for the input voltage range of 50 and 60 Hz and for protection category IP 55.

RENOVA

1RSC 29-40

| Curve No. | Model | Freq. (Hz) | Power (KW) | Max. Flow (m3/h) | Max. Vacuum (mbar) | Max. Pressure (mbar) | Voltage (V) | Current (A) | Inlet / Outlet | Noise (dBA) | Weight (Kg) |
|-----------|-----------------|------------|------------|------------------|--------------------|----------------------|---------------------|-------------|----------------|-------------|-------------|
| 1 | 1RSC29/40 0.85T | 50 | 0.85 | 145 | -160 | 160 | 200-240Δ / 345-415Y | 4.2Δ / 2.4Y | G 1½" | 63 | 16 |
| | | 60 | 0.95 | 175 | -160 | 160 | 220-275Δ / 380-480Y | 4.0Δ / 2.3Y | | 64 | |
| 2 | 1RSC29/40 1.3T | 50 | 1.3 | 145 | -170 | 200 | 200-240Δ / 345-415Y | 5.7Δ / 3.3Y | G 1½" | 63 | 17 |
| | | 60 | 1.5 | 175 | -210 | 220 | 220-275Δ / 380-480Y | 5.7Δ / 3.3Y | | 64 | |
| 3 | 1RSC29/40 0.85M | 50 | 0.8 | 145 | -150 | 160 | 115 / 230 | 10.4 / 5.2 | G 1½" | 63 | 15 |
| | | 60 | 0.9 | 175 | -160 | 140 | 115 / 230 | 11.6 / 5.8 | | 64 | |
| 4 | 1RSC29/40 1.1M | 50 | 1.1 | 145 | -180 | 190 | 115 / 230 | 14.6 / 7.3 | G 1½" | 63 | 16 |
| | | 60 | 1.3 | 175 | -180 | 190 | 115 / 230 | 16.6 / 8.3 | | 64 | |

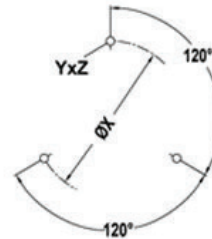
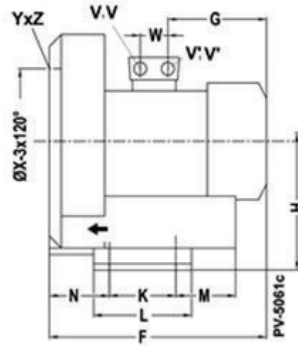
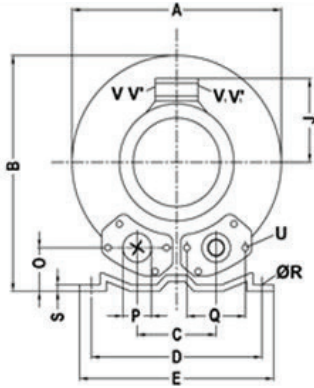

| Model | A | B | C | D | E | F | G | H | J | K | L | M | N | O | ØP |
|-----------------|-----|-----|-----|-----|-----|-----|-----|-----|-----|----|-----|----|----|----|-----|
| 1RSC29/40 0.85T | 286 | 302 | 115 | 225 | 255 | 292 | 160 | 154 | 120 | 95 | 130 | 70 | 75 | 46 | 1½" |
| 1RSC29/40 1.3T | 286 | 302 | 115 | 225 | 255 | 292 | 160 | 154 | 120 | 95 | 130 | 70 | 75 | 46 | 1½" |
| 1RSC29/40 0.85M | 286 | 302 | 115 | 225 | 255 | 294 | 160 | 154 | 120 | 95 | 130 | 70 | 75 | 46 | 1½" |
| 1RSC29/40 1.1M | 286 | 302 | 115 | 225 | 255 | 294 | 160 | 154 | 120 | 95 | 130 | 70 | 75 | 46 | 1½" |