

CATALOGUE

Gear Pumps



Positive displacement external gear pumps.
All-purpose lubrication, feed and process pumps.

INDEX

1. Introduction	5
1.1 Gvr Pompe technology, reliability, people. Our genetic heritage	6
1.2 SI Units and conversion equations	7
1.3 Engineering formulae for gear pumps	8
1.4 Function mode of gear pumps	8
1.5 Applications and suitable fluids	9
2. General information	
Standard Operating Conditions and Common Design Features	11
2.1 Range of pumps	12
2.2 Nomenclature	14
2.3 Standard operating conditions	16
2.3.1 Fluid viscosity and degree of contamination	16
2.3.2 Ambient and fluid temperature	17
2.3.3 NPSHr and operating pressures	18
2.4 Materials, painting and nameplate	18
2.4.1 Materials	18
2.4.2 Painting	19
2.4.3 Nameplate	19
3. APF Serie	
High Pressure Gear Pumps	21
3.1 Main characteristics and nominal flow rates	22
3.2 Main options	23
3.3 Sense of rotation and flow direction	24
3.4 Shaft-end seals	25
3.5 Pressure relief valve	25
3.6 Motorization	26
3.7 Accessories	26
3.8 Sound level	27
3.9 Pump selection and performance data	28
3.10 Overall dimensions and weights	30
3.10.1 APF	30
3.10.2 APF with IEC electric motor	32
3.11 Spare Parts	34
4. BMF, BCF, BFC Series	
Monobloc Gear Pumps, Bell-Coupling Gear Pumps	37
4.1 Main characteristics and nominal flow rates	38
4.2 Main options	40
4.3 Sense of rotation and flow direction	41
4.4 Shaft-end seals	42
4.5 Pressure relief valve	44
4.6 Version for aggressive liquids and environments	43
4.7 Motorization	43
4.8 Accessories	43
4.9 Pump selection and performance data	44
4.10 Integrated electric motors available on pumps BMF and BCF	46
4.11 Sound level	48
4.12 Overall dimensions and weights	49
4.12.1 BMF, BCF	49
4.12.2 BFC	50
4.12.3 BFC with IEC electric motor	52
4.13 Spare Parts	54
5. B, BC, MBM, MBMC Series	
Gear Pumps with Bare Shaft and Feet Mounting, Gear Pumps on Skid with Motor, Heating Chamber Version, ATEX version	57
5.1 Main characteristics and nominal flow rates	58
5.2 Main options	60
5.3 Sense of rotation and flow direction	60
5.4 Pressure relief valve	61
5.5 Shaft-end seals	62
5.6 Skid version with electric motor and coupling (MBM, MBMC)	63
5.7 Version for aggressive liquids and environments	65
5.8 Version with heating Chamber (BC, MBMC Series)	65
5.9 Version for hazardous areas (ATEX)	66
5.9.1 The Atex Directives	66
5.9.2 The Atex pumps features	67
5.9.3 The Atex pumps conformity and marking	67
5.10 Accessories	67
5.11 Sound level	68
5.12 Pump selection and performance data	69
5.13 Overall dimensions and weights	72
5.13.1 B	72
5.13.2 BC	77
5.13.3 MBM, MBMC	81
5.14 Spare Parts	88

1

Introduction

1.1 GVR POMPE

TECHNOLOGY, RELIABILITY, PEOPLE.

OUR GENETIC HERITAGE.

Who we are

Since 1956, the year in which Cavaliere of the Italian Republic Guglielmo Vagliani founded GVR Pompe, we are specialised in the manufacturing of gear pumps intended for both the Italian and international market.

For more than half a century our company has been family-run: technology, reliability and people represent our genetic heritage handed down to the third generation of the Beltrami family, today at the head of GVR Pompe.

Our headquarter is located in the industrial pole of Pieve Emanuele (Milan). The company is spread over a covered area of about 1.000sqm and an area of 500sqm used as offices.

Here we design, manufacture and customize a wide range of gear pumps according to the customer requirements and needs. We invest in the constant research of new materials and treatments using last generation machineries.

With the entry into the company of the third generation, GVR Pompe has evolved and had significant growth over recent years. Strengthened by physical and procedural restructuring, today we can offer to our customers products even more efficient, based on those strengths that have always distinguished us on the market. The totally Italian production and our ability to customize gear pumps are very valuable and recognized features by the leading companies that come to us for over sixty years.

GVR Pompe is both a family reality made up of people and strong relationships and a great company able to relate with every partner in the market, small or big, near or far.

Corporate Philosophy

For more than half a century technology, reliability and people represent our genetic heritage.

Technology

We focus on R&D activities and we pay great attention to the selection and training of engineers and technicians who contribute to the design and manufacture. Thanks to the skills, the experience gained in over half a century and the use of advanced machinery, we create innovative and technological products which meet all market needs.

Reliability

We grant to all customers innovative and quality products. Strength, technological flexibility, ease of use and limited maintenance over time are the main features of our gear pumps. Thanks to the totally Italian production we offer the best quality standard, verified during each stage of the design and manufacture process.

People

The client comes first. Our family dimension allows us to ensure promptness in response and special attention to everyone's needs. We have built and sustained over the time serious, professional and transparent relationships with customers all around the world. We follow you from the first contact, through the support during installation, until the end of the product life cycle. We always remain available to provide our know-how as manufacturers.

Products

Our gear pumps transfer viscous lubricating liquids without any suspended solids and they are used in the metallurgical, iron and steel, chemical, food and in the construction industry.

The full range is realized inside GVR Pompe. In our factory, located in Pieve Emanuele, we personally follow the different stages of research and development, design, industrialization, production and manufacturing, the quality review and the customization of the products.

With over 60 years of experience in manufacturing pumps, we can customize all kind of products according to client's needs.

Certifications

The search for the highest quality is for GVR Pompe both a duty towards customers and a philosophy on which the corporate life is founded.

The dedication to quality involves the entire range of products which are manufactured according to the Machinery Directive and subjected to scrupulous tests in our laboratory.

We work following the ISO 9001:2015 Quality System, which defines the procedures and sets the criteria that the product must fulfil in order to be placed on the market.

Certifications and standards of our products:

- CE Certification in accordance with the Machinery Directive 2006/42/CE
- UNI EN ISO 9001:2015 Certification
- Atex Certificate in accordance with the Directive 2014/34/EU and the Directive 99/92/EC
- EAC Certification

Certifications on request:

- RINA Certificate
- LLOYD'S Certificate
- DNW-GL Certificate
- UL/CSA Certificate

1.2 SI UNITS AND CONVERSION EQUATIONS

Tab. 101 - SI Units and conversion equations

Description	Formula symbol	Unit symbol	Unit name	Conversion equations
Distance	L	m	metre	$1 \text{ m}^3 = 1000 \text{ dm}^3$
Area	A	m^2	square metre	$1 \text{ dm}^3 = 1 \text{ L}$
Volume	V	m^3	cubic metre	
Angle in one plane	α	rad	radian	$1^\circ = \pi / 180 \text{ rad}$
				$1' = 1^\circ / 60$
				$1'' = 1' / 60$
Time	t	s	second	
Frequency	f	Hz	Hertz	$1 \text{ Hz} = 1/\text{s}$
Speed	v	m/s		
Angular speed	ω	rad/s		
Rotational speed	n	1/min		
Acceleration	a	m/s^2		
Angular acceleration	α	rad/s^2		
Mass	m	kg	kilogram	
Density	ρ	kg/m^3		
Force	F	N	Newton	$\text{N} = \text{kg} \times \text{m}/\text{s}^2$
				$\text{kg}_f = 9,81 \text{ N}$
Pressure	p	Pa	Pascal	$\text{Pa} = \text{N}/\text{m}^2$
				$\text{bar} = 10^5 \text{ Pa}$
Work / Energy	W	J	Joule	$\text{J} = \text{N} \times \text{m}$
				$1 \text{ kWh} = 3.6 \times 10^6 \text{ J}$
Torque	M	Nm		
Power	P	W	Watt	$\text{W} = \text{J}/\text{s}$
				$\text{W} = \text{Nm}/\text{s}$
Dynamic viscosity	μ	$\text{Pa} \cdot \text{s}$		$10^{-3} \text{ Pa} \cdot \text{s} = 1 \text{ cP (centipoise)}$
Kinematic viscosity	ν	m^2/s		$10^{-6} \text{ m}^2/\text{s} = 1 \text{ cSt (centistoke)}$
Electric current	I	A	Ampere	$\text{A} = \text{W}/\text{V}$
Electric voltage	U	V	Volt	$\text{V} = \text{W}/\text{A}$
Absolute Temperature	T (K)	K		
Temperature difference	ΔT	K	Kelvin	$1 \text{ K} = 1^\circ \text{C}$
Relative Temperature	T ($^\circ\text{C}$)	$^\circ\text{C}$	Degree Celsius	$0 \text{ K} = -273.15^\circ \text{C}$

1.3 ENGINEERING FORMULAE FOR GEAR PUMPS

Dynamic and Kinematic Viscosity

Conversion from dynamic (absolute) viscosity to kinematic viscosity (ν)

$$\nu = \mu / \rho \text{ [cSt]}$$

μ = dynamic viscosity [cP]
 ρ = specific mass [kg/dm³]

Fluid Velocity

Calculation of the velocity (ν) of a fluid flowing in a pipe

$$\nu = Q / (6 \cdot A) \text{ [m/s]}$$

Q = flow rate [L/min]
 A = pipe section [cm²]

Actual Delivery

Calculation of the actual flow rate (Q_{eff}) for a gear pump

$$Q_{\text{eff}} = V_{\text{geo}} \cdot n \cdot \eta_{\text{vol}} / 1000 \text{ [L/min]}$$

V_{geo} = geometrical displacement [cm³/rev]
 n = speed [1/min]
 η_{vol} = pump volumetric efficiency

Driving Torque

Calculation of the required torque at shaft end (M_{mec}) for a gear pump

$$M_{\text{mec}} = (V_{\text{geo}} \cdot \Delta p) / (62,8 \eta_{\text{hm}}) \text{ [Nm]}$$

V_{geo} = geometrical displacement [cm³/rev]
 Δp = differential pressure (discharge pressure - inlet pressure) [bar]
 η_{hm} = pump hydromechanical efficiency

Driving Power

Calculation of the required power at shaft end (P_{mec}) for a gear pump

$$P_{\text{mec}} = (Q_{\text{eff}} \cdot \Delta p) / (600 \cdot \eta_{\text{hm}} \cdot \eta_{\text{vol}}) \text{ [kW]}$$

Q_{eff} = actual delivery [L/min]
 Δp = differential pressure (discharge pressure - inlet pressure) [bar]
 η_{hm} = pump hydromechanical efficiency
 η_{vol} = pump volumetric efficiency

Overall Pump Efficiency

Calculation of the overall efficiency (η_{tot}) for a gear pump

$$\eta_{\text{tot}} = \eta_{\text{hm}} \cdot \eta_{\text{vol}}$$

η_{hm} = pump hydromechanical efficiency
 η_{vol} = pump volumetric efficiency

The values for the efficiencies depend on pump type, differential pressure, speed, fluid viscosity and temperature. Please ask to our Technical Department for specific values.

1.4 FUNCTION MODE OF GEAR PUMPS

Gear pumps are rotating positive displacement pumps.

Through the rotation of two helical gears, the medium enclosed between the teeth space, is transferred from the suction side to the pressure side.

The flow of the medium leads to a pressure decrease on the suction side, which is compensated by the continuous

flowing of the liquid, that maintains the delivery process. Gear pumps are self-priming. They are capable of draining the suction pipe until the same has been completely filled with the liquid flow.

A fluid volume proportional to the speed is displaced by the rotation. Gear pumps have a basically constant flow even when the delivery pressure changes during operations.

Fig. 101 – Gear pumps delivery principle

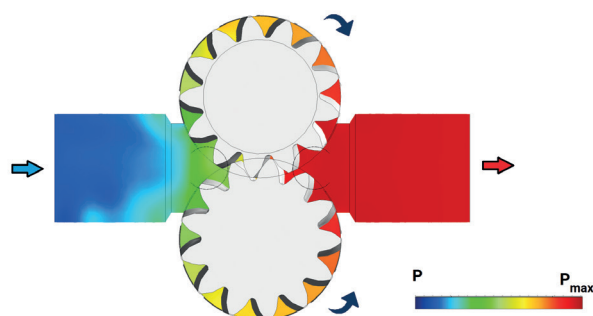

1.5 APPLICATIONS AND SUITABLE FLUIDS

Gear pumps transfer medium and high viscosity fluids, with a minimum amount of lubricating properties. The liquid must not contain any solids and must be chemically compatible with the materials of construction.

Gear pumps have a wide range of applications: general engineering, construction machines, mining industry, chemical industry, diesel engines, printing machines, electric motor construction, automotive engineering, gas turbines, foundry technology, wood machining, industrial gear transmissions, refrigeration technology, compressor manufacturing, power generation, cogeneration plants, paper machines, pump industry, shipbuilding, textile machines, water turbines, rolling mills, tooling machines, wind energy generation, cement plant construction, agriculture industry.

Some typical applications are:

- Generation of industrial process heat (THERMAL OIL)
- Paint industry and printing machines (PAINT, PRINTING INKS)
- Waste oil disposal transport and treatment (WASTE OIL)
- Power plants, turbines, wind generators (LUBRICATING OIL)
- Tank and silos plants
- Polyurethane machinery (POLYOL and ISOCYANATE)
- Foods for animal breeding (MOLASSES)
- Fire fighting systems (FOAMS)
- Chemicals dosing machines (CHEMICALS)
- Metal industry (DRAWING COMPOUND)

Gear pumps are mostly used with fluids such as: Additives, Adhesives, Antifreeze, Diesel oils, Drawing compound, Emulsions, Engine oils, Fuel oils (L, EL, H), Gear oils, Glycol, Grease, Hardening oils, Heat transfer media, Heavy oils, Hydraulic fluids, Isocyanate, Lubricating oils, Molasses, Paints, Paraffins, Plastics, Polyols, Printing inks, Processing oils, Resins, Waste oils, Waxes.

Tab. 102 – Kinematic viscosity at operating temperatures of the most common fluids

Fluid	Kinematic viscosity [cSt] at temperature of								
	0°C	10°C	20°C	25°C	40°C	50°C	60°C	80°C	100°C
Water	1.8	1.3	1			0.55		0.36	0.28
Diesel oil					3.3				
Biodiesel					5.0				
Naphtha					7.4				
Caustic hydroxide			10.5						
Firefighting Foam			17						
Isocyanate				66					
Polyol				110					
Oil ISO 32		260	85	70	32	21.8	15	8.4	5.4
Oil ISO 46		270	143	104	46	30	20.5	11.2	6.9
Oil ISO 68		450	210	155	68	43	28.5	15	9
Low sulphur fuel oil						378			
Glucose					2900	1200	570		
Honey				7000					
Molasses		12000	8000					700	
Glue			11500						

2

General information

Standard operating
conditions and common
design features.

2.1 RANGE OF PUMPS

The product range is made of three main Series (APF, BMF, B) and their variants. They can be supplied in the following configurations:

MAIN FEATURES		SERIES	CONSTRUCTION	OUTPUT [L/min]	at SPEED [1/min]	VISCOSITY [cSt]	Max HEAD [bar]
High Pressure Gear Pumps for IM B34 motor (*)		APF	A = Cast Iron EN GJL 250	5 ÷ 80	1450	1÷1.000	25
Electric Gear Pumps with Integrated Motor (Monobloc)	Three-phase 4 Poles	BMF	A = Cast Iron EN GJL 250	2 ÷ 70	1450	1÷ 200	12
		BMF	E = Bronze EN CC491K				
		BMF	I = Stainless Steel AISI 316				
	Three-phase 6 Poles	BMF	A = Cast Iron EN GJL 250	3 ÷ 45	950	1 ÷ 700	
		BMF	E = Bronze EN CC491K				
		BMF	I = Stainless Steel AISI 316				
	Single-phase 4 Poles	BCF	A = Cast Iron EN GJL 250	2 ÷ 70	1450	1÷ 200	
		BCF	E = Bronze EN CC491K				
		BCF	I = Stainless Steel AISI 316				
	Single-phase 6 Poles	BCF	A = Cast Iron EN GJL 250	3 ÷ 15	950	1 ÷ 700	
		BCF	E = Bronze EN CC491K				
		BCF	I = Stainless Steel AISI 316				
Bell-Coupling Gear Pumps for IM B34 motor (*)		BFC	A = Cast Iron EN GJL 250	2 ÷ 70	1450	1÷1.000	12
		BFC	E = Bronze EN CC491K				
		BFC	I = Stainless Steel AISI 316	5 ÷ 70			
Gear Pumps with Bare Shaft and Feet Mounting; ATEX version available		B	A = Cast Iron EN GJL 250	5 ÷ 800	1450/700**	1÷20.000	12
		B	E = Bronze EN CC491K				
		B	I = Stainless Steel AISI 316				
	with heating chamber	BC	A = Cast Iron EN GJL 250	10 ÷ 400	1450		
		BC	I = Stainless Steel AISI 316				
Gear Pumps on Skid with Motor; ATEX version available		MBM	A = Cast Iron EN GJL 250	5 ÷ 800	1450/700**	1÷20.000	12
		MBM	E = Bronze EN CC491K				
		MBM	I = Stainless Steel AISI 316				
	with heating chamber	MBMC	A = Cast Iron EN GJL 250	10 ÷ 400	1450		
		MBMC	I = Stainless Steel AISI 316				

2.2 NOMENCLATURE

Tab. 202 – Nomenclature for pumps with motor

Value	BMF	35	-	A	E	-	V	6	G	1.1	-	2	00
Pos.	1a	1b		2	3	4	5	6	7	8	9	10	11

Example: Monobloc gear pump BMF size 35. Construction in cast iron, with mechanical seal in ceramic-graphite- viton, with relief valve. Pump with motor 6p, 230/400V 50Hz, 1.1kW, IP55, IE2.

POS. 1a Pump Series	BMF	Three-phase monobloc gear pump	POS. 5 Pump Protection	-	Without protection
	BCF	Single-phase monobloc gear pump		V	Pressure relief valve for pump in cast iron
	BFC	Bell-coupling gear pump		Z	Atex pump with pressure relief valve for pump in cast iron
	MBM	Gear pump B serie on skid with motor		W	Double pressure relief valve for pump in cast iron
	MBMC	Gear pump BC serie on skid with motor		M	Heatsink
	APF	High pressure gear pump		...	Other combination available
POS. 1b Size	n-nnnn	2 ÷ 1600	POS. 6 Poles	2	2 poles
				4	4 poles
POS. 2 Materials	A	Casing in cast iron, internal parts in steel, gaskets in viton or flexoid		6	6 poles
	E	Casing in bronze, internal parts in AISI 316, gaskets in viton or flexoid		8	8 poles
	I	Casing and internal parts in AISI 316, gaskets in viton or teflon		X	Special speed
	...	Other combination available	POS. 7 Voltage	E	230V 50Hz Single-phase
	X	Special construction		G	230/400V 50Hz - 265/460V 60Hz Three-phase (standard)
POS. 3 Seal	A	Lip seal in Viton		L	400/690V 50Hz - 460/795V 60Hz Three-phase (standard for motors ≥ 5.5kW)
	D	Teflon packing seal		...	Other combination available
	E	Mechanical seal in ceramic-graphite-viton		X	Special voltage
	G	Mechanical seal in widia-widia-viton	POS. 8 Electric Motor Power	nn.nn	rated power of electric motor kW
	...	Other combination available		POS. 9 Motor Protection	-
X	Special seal	A	Atex		
POS. 4 Bushings	G	Bushings in graphite	E		cURus/UL/CSA
	H	KU in inox	P		IP56
	K	KU in bronze	S		Forced ventilation
	P	Bushings in teflon	Y		Motor supplied by the customer
	...	Other combination available	...	Other combination available	
	X	Special bushings	X	Special motor protection	
POS. 10 Motor Efficiency	1	IE1	POS. 11 Progressive Number	00	Progressive number for standard pump
	2	IE2		0...	Progressive number for special features
	3	IE3			

Tab. 203 – Nomenclature for pumps without motor

Value	BFC	35	-	E	E	H	-	-	-	80	-	-	00
Pos.	1a	1b		2	3	4	5	6	7	8	9	10	11

Example: Gear pump BFC size 35 with bell and coupling for electric motor frame size 80. Motor not included. Construction in bronze, with mechanical seal in ceramic-graphite-viton, bushings in inox, without relief valve.

POS. 1a Pump Series	BFC	Bell-coupling gear pump
	B	Gear pump with bare shaft and feet mounting
	BC	Gear pump with bare shaft, feet mounting and heating chamber
	APF	High pressure gear pump
POS. 1b Size	n-nnnn	2 ÷ 1600
POS. 2 Materials	A	Casing in cast iron, internal parts in steel, gaskets in viton or flexoid
	E	Casing in bronze, internal parts in AISI 316, gaskets in viton or flexoid
	I	Casing and internal parts in AISI 316, gaskets in viton or teflon
	...	Other combination available
	X	Special construction
POS. 3 Seal	A	Lip seal in Viton
	D	Teflon packing seal
	E	Mechanical seal in ceramic-graphite-viton
	G	Mechanical seal in widia-widia-viton
	...	Other combination available
	X	Special seal
POS. 4 Bushings	G	Bushings in graphite
	H	KU in inox
	K	KU in bronze
	P	Bushings in teflon
	...	Other combination available
	X	Special bushings

POS. 5 Pump Protection	-	Without protection
	V	Pressure relief valve for pump in cast iron
	Z	Atex pump with pressure relief valve for pump in cast iron
	W	Double pressure relief valve for pump in cast iron
	M	Heatsink
	Y	Parts of customer property
	...	Other combination available
X	Special pump protection	
POS. 6	-	not applicable
POS. 7	-	not applicable
POS. 8 Electric Motor Size	-	not applicable
	nnn	Electric motor's frame size to be coupled to the flanged pump (56-63-71-80-90-100-112-132-...)
POS. 9	-	not applicable
POS. 10	-	not applicable
POS. 11 Progressive Number	00	Progressive number for standard pump
	0...	Progressive number for special features

2.3 STANDARD OPERATING CONDITIONS

2.3.1 Fluid viscosity and degree of contamination

The viscosity of the fluid affects the pump performances.

As a general rule low viscosities increase the slip. The slip is the percentage of fluid being pushed backward by the different pressure between delivery and suction through the gaps. Higher slips give a reduction of the volumetric efficiency.

On the other hand high viscosities increase friction losses causing a reduction of the pump mechanical efficiency.

The gear pumps range covers installations with fluid viscosities between 1 to 20.000 cSt.

Fluid impurities: the fluid should be filtered in order to avoid particles greater than 300 μm .

The maximum speed allowed should be checked according to the following curve:

Fig. 201 – Kinematic viscosity and maximum speed

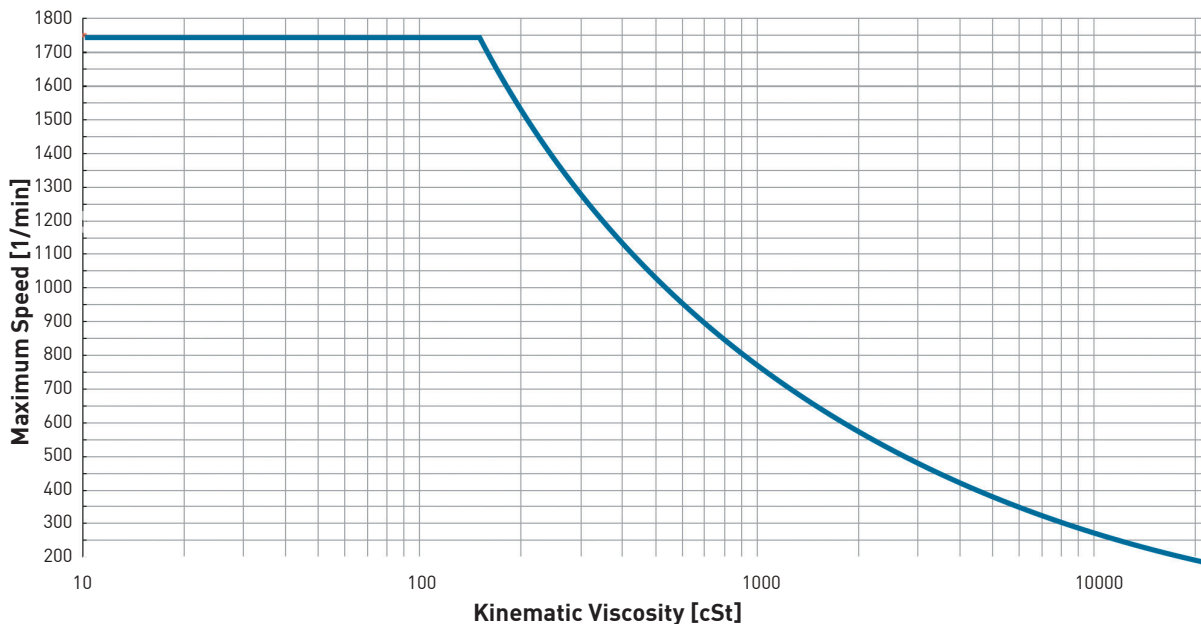

2.3.2 Ambient and fluid temperature

For the correct construction selection of the gear pump, it is recommended to consider both ambient and liquid temperature.

Tab. 204 – Operating temperatures

Version	Version description	Sealing type	Sealing material	Ambient temperature		Fluid temperature	
				Min [°C]	Max [°C]	Min [°C]	Max [°C]
A	Cast iron EN-GJL-250	Mechanical seal	Ceramic-graphite- viton	-20	60	-20	100
	Cast iron EN-GJL-250	Mechanical seal	Widia-widia- viton (*)	-20	60	-20	180
	Cast iron EN-GJL-250	Lip seal	Viton	-20	60	-20	100
	Cast iron EN-GJL-250	Packing seal	Teflon	-20	60	-20	200
E	Bronze EN-CC491K	Mechanical seal	Ceramic-graphite- viton	-20	60	-20	100
	Bronze EN-CC491K	Mechanical seal	Widia-widia- viton (*)	-20	60	-20	180
	Bronze EN-CC491K	Lip seal	Viton	-20	60	-20	100
	Bronze EN-CC491K	Packing seal	Teflon	-20	60	-20	200
I	Hardened AISI 316	Mechanical seal	Ceramic-graphite- viton	-40	60	-20	100
	Hardened AISI 316	Mechanical seal	Widia-widia- viton (*)	-40	60	-20	180
	Hardened AISI 316	Lip seal	Viton	-40	60	-20	100
	Hardened AISI 316	Packing seal	Teflon	-40	60	-20	200

(*) Special execution.

2.3.3 NPSHr and operating pressures

For a perfect operation and to avoid cavitation, the static pressure at the entry of the pump should never fall below -0.4 bar (0.6 bar absolute): NPSHr required.

It is always recommendable to calculate the NPSHa (available): the lowest static pressure that may occur at the pump's entry side during the operation considering all piping and filters resistances.

Pressure at the suction inlet (with bushings)
min 0.4 bar - max 10 bar

Differential pressure (Serie APF) max 25 bar

Differential pressure (Series BMF and B) max 12 bar

Higher operating pressure on request.

Max pressure in the heating chamber
(Series BC and MBMC) max 7 bar

2.4 MATERIALS, PAINTING AND NAMEPLATE

2.4.1 Materials

Tab. 205 - Materials

Component	Standard material			On request
	Cast iron version	Stainless steel version	Bronze version	
Pump housing	Cast Iron EN-GJL-250	Hardened AISI 316	Bronze EN-CC491K	
Pump cover	Cast Iron EN-GJL-250	Hardened AISI 316	Bronze EN-CC491K	
Shafts	Steel EN-18NiCrMo5	Hardened AISI 316L	Hardened AISI 316L	
Gears	Steel EN-C45E	Hardened AISI 316L	Hardened AISI 316L	PEEK, Technopolymer
Sleeve bushings	Steel-Bronze-PTFE, Sintered Bronze	AISI 316-Bronze-PTFE	AISI 316-Bronze-PTFE	PEEK, Graphite, PTFE
Mechanical seal	Ceramic-Carbon graphite-FPM	Ceramic-Carbon graphite-FPM	Ceramic-Carbon graphite-FPM	Several solutions according to the liquid
Lip seal	FPM (Viton)	FPM (Viton)	FPM (Viton)	PTFE, NBR
Packing seal	Acrylic yarn-PTFE	Acrylic yarn-PTFE	Acrylic yarn-PTFE	
Gaskets	Flexoid	Flexoid	Flexoid	PTFE, Copper, Asbestos-free
O-rings	FPM (Viton)	FPM (Viton)	FPM (Viton)	FEP, NBR, PTFE, FFPM (Kalrez)
Screws and nuts	Steel 8.8	Stainless Steel	Stainless Steel	
Pressure relief valve	Brass EN-0T58	AISI 316	AISI 316	
Electric motor	See manufacturer documentation			
Coupling	Aluminium	Aluminium	Aluminium	Cast Iron EN-GJL-250
Spider	Polyamide	Polyamide	Polyamide	Polyuretane
Coupling protection	Galvanized steel	Galvanized steel	Galvanized steel	Stainless steel
Skid	Galvanized steel	Galvanized steel	Galvanized steel	Stainless steel
Bell housing	Aluminium	Aluminium	Aluminium	

2.4.2 Painting

Tab. 206 - Painting

Main features	Description
Pretreatment	all castings are sandblasted, cleaned and degreased
Painting	final coat of epoxy-polyester water based paint, oven dried at 50°C
Thickness	30 µm
Colour	RAL 5010
Corrosion resistance	Highly resistant to water, water vapour
Chemical resistance	Good resistance in chemically aggressive environments

Special colours on request.

Special painting cycles on request, e.g. C3-C5.

2.4.3 Nameplate

Fig. 202 – Typical nameplate for pump without electric motor



Fig. 203 – Typical nameplate for electric pump

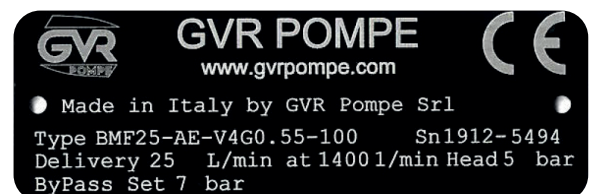



3

APF Serie

High Pressure Gear Pumps.

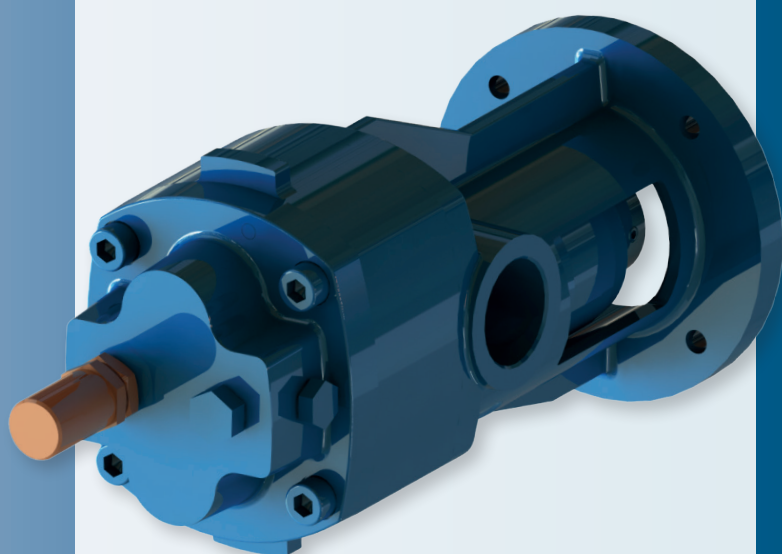

3.1 MAIN CHARACTERISTICS AND NOMINAL FLOW RATES

APF pumps are volumetric gear pumps suitable for transferring lubricant viscous liquids without any suspended solids or abrasive substances. They are self-priming pumps used for a wide range of liquids with a viscosity from 1 to 1000 cSt (when driven by a standard industrial electric motor). The speed of rotation is chosen according to the viscosity of the liquid. Flowrate range is from 5 to 80 L/min. These pumps are designed to reach a maximum pressure of 25 bar.

The standard construction consists of pump housing and cover in cast iron, shafts and gears in carbon steel,

O-rings in Viton, sleeve bushings in sintered bronze and mechanical seal in ceramic-graphite-Viton. APF pumps are supplied with a pressure relief valve in brass.

Nozzles in inlet and outlet are of the same diameter and positioned on the same axis.

A short and straight alignment of the flow channels provides for a good suction capability and a quiet running. The helical gears result in extremely low noise levels and reduced pressure pulsation.

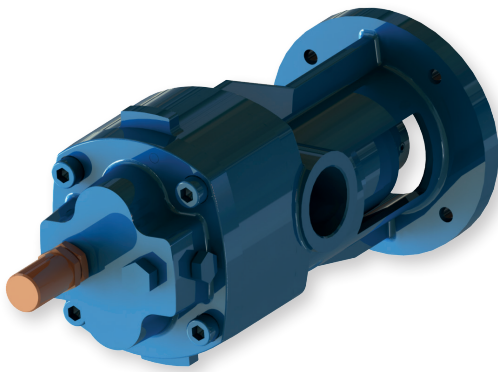
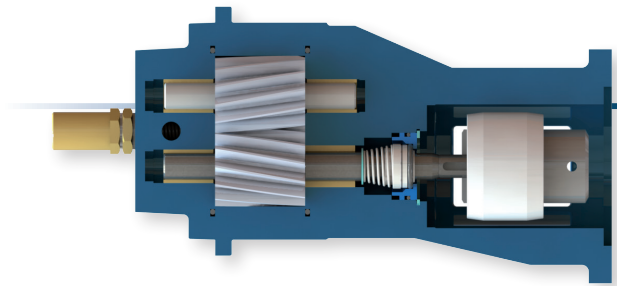

Fig. 301 – APF pump, standard version



APF are bare shaft pumps designed to be coupled to an IEC electric motor IMB34 by means of coupling.

The electric motor can be supplied on request. Available flanges are listed as follows:

Tab. 301 - Flanges available for coupling to IEC electric motors IM B34

PUMP SIZE (APF)	IEC Frame size				
	71	80	90	100	112
	Flange [mm]				
	105	120	140	160	160
5					
10					
15					
20					
25					
30					
40					
50					
60					
70					
80					

Table 302 shows the possible flow rates for non-pressurized pumping ($\Delta p=0$) and a 46 cSt fluid. The flow rate of gear pumps is virtually proportional to their

speed. The selected speeds are the most common speeds at rated power of industrial electric motors at 50 and 60Hz.

Tab. 302 – Nominal flow rates

PUMP SIZE (APF)	Geometrical displacement V_{geo} [cm ³ /rev]	Nominal flow rate Q_{teo} [L/min] at Speed n [1/min]					
		690	830	950	1150	1450	1750
5	4.6	3.1	3.8	4.3	5.2	6.6	8.0
10	9.1	6.3	7.5	8.6	10.5	13.2	15.9
15	13.6	9.4	11.3	12.9	15.7	19.8	23.9
20	15.9	11.0	13.2	15.1	18.3	23.1	27.8
25	18.2	12.5	15.1	17.3	20.9	26.4	31.8
30	23.4	16.2	19.4	22.2	26.9	33.9	41.0
40	28.1	19.4	23.3	26.7	32.3	40.7	49.1
50	36.3	25.1	30.1	34.5	41.8	52.7	63.6
60	43.6	30.1	36.2	41.4	50.1	63.2	76.3
70	50.9	35.1	42.2	48.3	58.5	73.7	89.0
80	58.1	40.1	48.2	55.2	66.8	84.3	101.7

3.2 MAIN OPTIONS

The main options available are:

- Clockwise rotation (see paragraph 3.3)
- Special seals according to liquids and temperatures (see paragraph 3.4)
- Options on relief valve (see paragraph 3.5)
- Motors (see paragraph 3.6)
- Accessories (see paragraph 3.7)

3.3 SENSE OF ROTATION AND FLOW DIRECTION

The standard version of APF pumps can operate only in one direction of rotation: counterclockwise watching the pump shaft end.

The direction of the fluid flow is shown by an arrow placed nearby the piping connections.

A proper mounting will keep the nameplate on the top side. In this case the flow direction will be from the left side to the right side watching the pump shaft end and the pressure side (delivery) will be at the right-hand side.

On request a clockwise version can be supplied.

Fig. 302 – Sense of rotation and flow direction

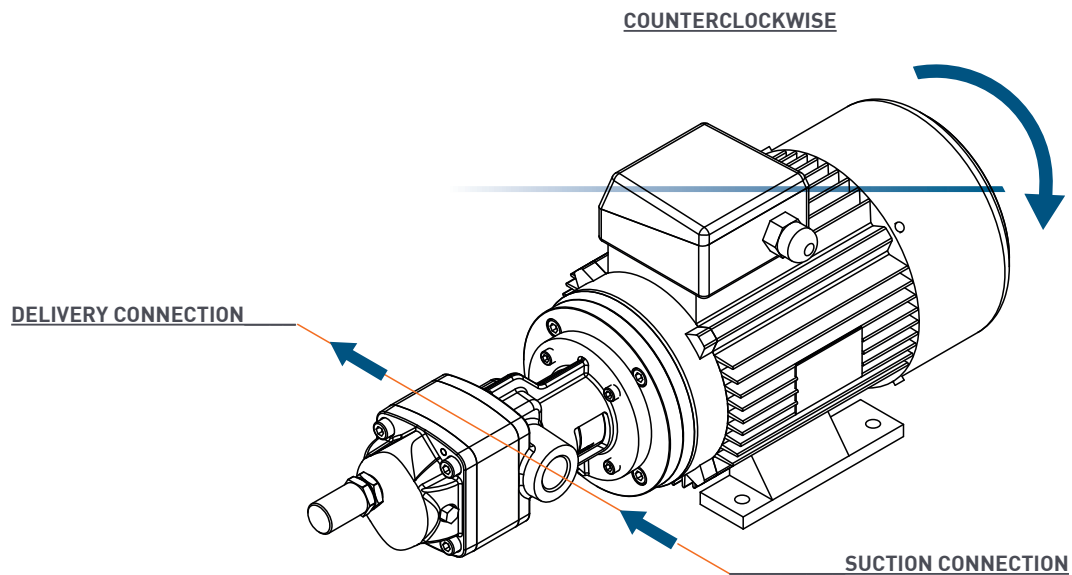

3.4 SHAFT-END SEALS

The standard version is fitted with mechanical seal in ceramic-graphite-FPM. A number of different seals materials can be supplied for different liquids and operating temperatures.

On request:

- Radial lip-type seal in FPM (Viton), NBR or PTFE (Teflon)
- Seal for high temperatures up to 200°C
- Reversible mechanical seal

Fig. 303 – Mechanical seal

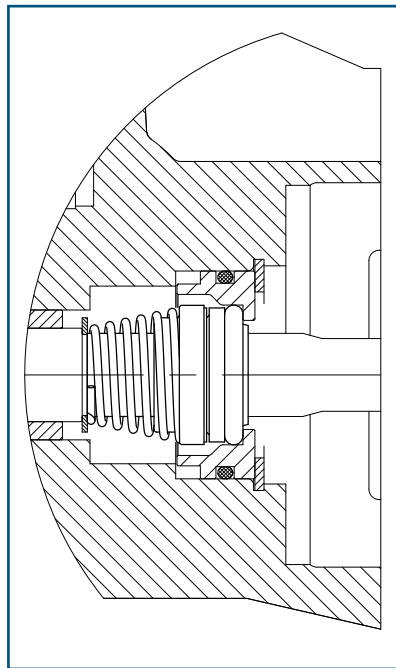
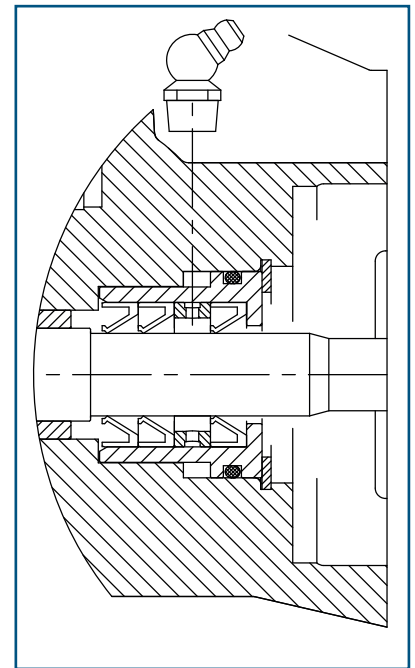

Fig. 304 – Lip seal



3.5 PRESSURE RELIEF VALVE

APF pumps are supplied with a brass pressure relief valve as a standard. It works only on outlet, in one direction.

It may be used as a safety valve only for short-term operations. When a partial discharge flow has to be drained over a prolonged period of time, a separate by-pass valve with return to the suction tank has to be installed into the piping.

The pressure relief valve is designed as a spring-preloaded piston valve. It is integrated into the pump's end cover.

The spring pretension and the relative opening pressure can be adjusted by means of a screw. Different springs are also available to reach the desired adjustment range.

As an option the pumps can be supplied without relief valve.

3.6 MOTORIZATION

The most common installed electric motors have the following characteristics:

- Standard motors in IP55, insulation class F available at 4, 6 and 8 poles
- Standard voltages for Three-phase motors $\leq 4\text{kW}$ 230/400V 50Hz - 265/460V 60Hz
- Standard voltages for Three-phase motors $\geq 5,5\text{kW}$ 400/690V 50Hz - 460/795V 60Hz
- Standard voltages for Single-phase motors 230V 50Hz.

Special options on electric motors:

- Atex motors
- Motors with built-in frequency converter
- Motors suitable for frequency converter connection
- Motor with forced ventilation

- Tropicalization
- Special voltages
- Protection IP56/IP65
- Protection IP67/IP68
- Thermistors PTC
- Special treatment for corrosive and saline environment
- Motors according to UL-CSA, NEMA, cURus and Marine regulations
- Insulation class H

Special motors available:

- Internal combustion engines
- Gearmotor
- Mechanical variator
- DC motors at 12V and 24V

3.7 ACCESSORIES

- Pump on trolley
- Control panel
- ON/OFF switches
- Reversing switches
- Piping
- Heated piping
- Valves
- Pressure gauge and pressure switch
- Electric cables

3.8 SOUND LEVEL

The sound level has been measured in dB(A) at 1m distance, at 1450 1/min with a gear oil (viscosity 46 cSt).

Tab. 303 – Sound level

PUMP SIZE (APF)	Sound level dB(A) at pressure			
	5 bar	10 bar	15 bar	25 bar
5	72	73	74	80
10	72	73	74	80
15	72	73	74	80
20	72	73	74	80
25	72	73	74	80
30	74.5	75	77	80
40	74.5	75	77	80
50	74.5	75	77	80
60	74.5	75	77	80
70	74.5	75	77	80
80	74.5	75	77	80

3.9 PUMP SELECTION AND PERFORMANCE DATA

In table 304 are listed the actual delivery Q_{eff} and required power P_{mec} for each pump size at different speeds and pressures.

The data refers to a mineral oil ISO46 (Kinematic viscosity 46 cSt at 40°C).

The rated power for the drive motor should be 20% higher than the required power P_{mec} .

For different viscosities please ask the performances (delivery and power) to our Technical department.

As a general rule the flow rate is approximately proportional to the speed.

A lower viscosity may lead to a loss of the net delivery and a higher viscosity may lead to an increase of the net delivery.

When dimensioning please consider the maximum viscosity, usually at the start-up phase.

Pump selection, delivery and required power at different speeds:

- 1) Given the project delivery Q_{pro} [L/min] and speed n_{pro} [1/min] calculate the project displacement V_{pro} [cm³/rev]:

$$V_{\text{pro}} = 1000 \times Q_{\text{pro}} / n_{\text{pro}}$$

- 2) Select the Pump Type with the geometrical displacement V_{geo} closer to V_{pro} ,

- 3) Read from the Performance Table the delivery at 1450 1/min and at the given pressure p:

$$Q_{1450, p} \text{ [L/min]}$$

- 4) Calculate the actual delivery Q [L/min] at n_{pro} and p:

$$Q = Q_{1450, p} + V_{\text{geo}} \times (n_{\text{pro}} - 1450) / 1000$$

- 5) Read from the Performance Table the required power and actual delivery of the selected Pump Type at the closer speed n_{x} to n_{pro} and at p:

$$P_{n_x, p} \text{ [kW]}, Q_{n_x, p} \text{ [L/min]}$$

- 6) Calculate the actual required power P at n_{pro} and p [kW]:

$$P = P_{n_x, p} \times Q / Q_{n_x, p}$$

Tab. 304 - Performance data at 690, 830, 950, 1150, 1450, 1750 1/min and 46 cSt

PUMP SIZE (APF)	Geometrical displacement V_{geo} [cm ³ /rev]	Pressure p [bar]	Speed n [1/min]											
			690		830		950		1150		1450		1750	
			Q_{eff} [L/min]	P_{mec} [kW]	Q_{eff} [L/min]	P_{mec} [kW]	Q_{eff} [L/min]	P_{mec} [kW]	Q_{eff} [L/min]	P_{mec} [kW]	Q_{eff} [L/min]	P_{mec} [kW]	Q_{eff} [L/min]	P_{mec} [kW]
5	4.6	5	2.9	0.09	3.5	0.11	4.0	0.12	4.9	0.14	6.2	0.2	7.5	0.2
		10	2.7	0.2	3.2	0.2	3.7	0.2	4.6	0.3	5.8	0.4	7.1	0.5
		15	2.4	0.2	3.0	0.3	3.4	0.3	4.2	0.4	5.4	0.5	6.7	0.7
		25	1.9	0.4	2.4	0.5	2.8	0.6	3.6	0.7	4.7	0.9	5.8	1.1
10	9.1	5	5.8	0.2	7.1	0.2	8.1	0.2	9.8	0.3	12.5	0.3	15.1	0.4
		10	5.4	0.3	6.6	0.3	7.6	0.4	9.2	0.5	11.8	0.6	14.3	0.8
		15	5.0	0.4	6.1	0.5	7.0	0.6	8.6	0.7	11.0	0.9	13.5	1.1
		25	4.1	0.7	5.1	0.8	6.0	1.0	7.4	1.2	9.6	1.5	11.9	1.9
15	13.6	5	8.8	0.2	10.7	0.3	12.2	0.3	14.8	0.4	18.7	0.5	22.6	0.7
		10	8.3	0.3	10.0	0.4	11.5	0.5	13.9	0.6	17.7	0.9	21.4	1.1
		15	7.7	0.5	9.3	0.6	10.7	0.7	13.1	0.9	16.6	1.2	20.2	1.5
		25	6.6	0.7	8.0	0.9	9.2	1.0	11.3	1.3	14.5	1.8	17.7	2.2
20	15.9	5	10.2	0.2	12.3	0.3	14.1	0.3	17.2	0.4	21.8	0.5	26.5	0.7
		10	9.3	0.4	11.4	0.5	13.1	0.6	16.1	0.7	20.5	0.9	25.1	1.2
		15	8.5	0.6	10.5	0.7	12.1	0.8	15.0	1.0	19.3	1.3	23.7	1.7
		25	6.9	0.9	8.6	1.2	10.1	1.3	12.7	1.7	16.8	2.2	21.0	2.7
25	18.2	5	11.5	0.4	13.9	0.5	16.0	0.5	19.5	0.6	24.7	0.6	30.0	0.6
		10	10.5	0.7	12.7	0.8	14.7	0.9	18.1	1.0	23.1	1.1	28.2	1.2
		15	9.4	0.9	11.6	1.1	13.4	1.2	16.6	1.4	21.5	1.6	26.5	1.8
		25	7.3	1.4	9.2	1.7	10.9	1.9	13.8	2.2	18.3	2.7	22.9	3.1
30	23.4	5	14.8	0.5	18.0	0.5	20.7	0.6	25.3	0.6	32.3	0.8	39.4	1.0
		10	13.5	0.9	16.5	1.0	19.2	1.1	23.8	1.2	30.7	1.4	37.8	1.7
		15	12.1	1.3	15.1	1.5	17.7	1.6	22.2	1.8	29.1	2.1	36.3	2.4
		25	9.4	2.0	12.2	2.4	14.7	2.6	19.0	3.0	25.9	3.4	33.1	3.8
40	28.1	5	19.5	0.5	23.5	0.6	27.0	0.8	32.8	1.0	41.5	1.4	50.1	1.8
		10	19.0	1.0	23.0	1.2	26.4	1.4	32.1	1.7	40.8	2.2	49.4	2.6
		15	18.4	1.4	22.4	1.7	25.8	1.9	31.5	2.4	40.1	3.0	48.7	3.5
		25	17.3	2.3	21.2	2.7	24.5	3.1	30.2	3.7	38.8	4.6	47.3	5.3
50	36.3	5	22.5	0.6	27.7	0.7	32.3	0.8	40.0	1.0	51.5	1.4	62.2	1.7
		10	19.9	0.8	25.2	1.1	30.0	1.3	38.3	1.7	50.4	2.3	60.8	2.9
		15	17.3	1.1	22.8	1.5	27.8	1.8	36.5	2.5	49.2	3.3	59.5	4.0
		25	12.1	1.5	17.9	2.2	23.3	2.8	33.0	3.9	46.9	5.3	56.8	6.2
60	43.6	5	29.1	0.6	35.1	0.7	40.3	0.9	48.8	1.1	61.6	1.5	74.3	1.9
		10	28.2	1.0	34.1	1.2	39.1	1.4	47.4	1.8	59.9	2.4	72.4	3.0
		15	27.2	1.5	33.1	1.7	38.0	2.0	46.1	2.5	58.3	3.3	70.5	4.2
		25	25.3	2.3	31.0	2.7	35.7	3.2	43.4	4.0	55.0	5.2	66.6	6.5
70	50.9	5	33.4	0.7	40.3	0.8	46.3	1.0	56.3	1.3	71.4	1.7	86.5	2.1
		10	31.7	1.2	38.5	1.4	44.3	1.7	54.1	2.1	69.0	2.7	84.0	3.4
		15	30.0	1.6	36.6	2.0	42.3	2.4	51.9	2.9	66.6	3.7	81.5	4.6
		25	26.6	2.6	32.8	3.2	38.3	3.7	47.6	4.6	61.8	5.8	76.4	7.0
80	58.1	5	39.4	0.8	47.5	1.0	54.3	1.2	65.8	1.5	83.0	2.0	100.3	2.6
		10	38.7	1.3	46.7	1.6	53.5	1.9	64.8	2.4	81.8	3.3	98.9	4.1
		15	38.1	1.8	45.9	2.3	52.6	2.7	63.8	3.4	80.6	4.5	97.4	5.6
		25	36.7	2.9	44.3	3.6	50.8	4.2	61.7	5.3	78.1	6.9	94.6	8.7

Different viscosities, working pressure, rotational speed and ambient conditions can change performance data shown in the table.

3.10 OVERALL DIMENSIONS AND WEIGHTS

3.10.1 APF

Fig. 305 - APF dimensional drawing

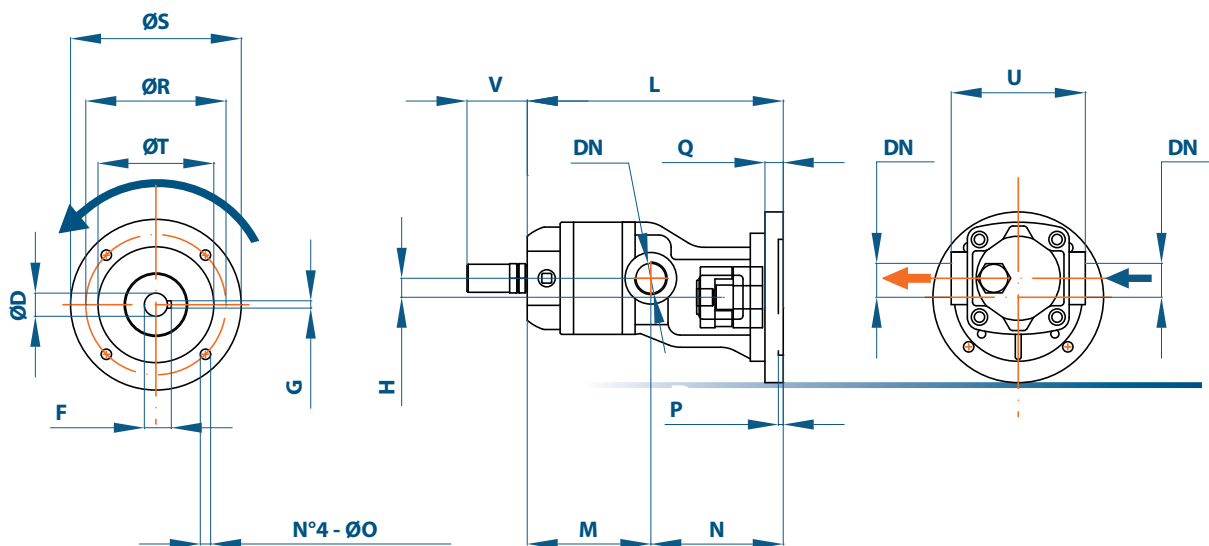

Tab. 305 – APF overall dimensions and weight

PUMP SIZE (APF)	for IEC electric motor		DN ISO 228-1	D	F	G	H	L	M	N	O	P	Q	R	S	T	U	V	Weight [kg]
	Frame size	IM																	
5	71	B34	G 1/2"	14	16.3	5	16	166	72	94	7	4	13	85	105	70	110	50	5.8
	80	B34	G 1/2"	19	21.8	6	16	166	72	94	7	4	13	100	120	80	110	50	6
10	71	B34	G 3/4"	14	16.3	5	16	176	82	94	7	4	13	85	105	70	110	50	5.9
	80	B34	G 3/4"	19	21.8	6	16	176	82	94	7	4	13	100	120	80	110	50	6.1
15	80	B34	G 3/4"	19	21.8	6	16	185	91	94	7	4	13	100	120	80	110	50	6.5
	90	B34	G 3/4"	24	27.3	8	16	198	91	107	8.5	4	13	115	140	95	110	50	7.3
20	80	B34	G 3/4"	19	21.8	6	16	190	96	94	7	4	13	100	120	80	110	50	6.7
	90	B34	G 3/4"	24	27.3	8	16	203	96	107	8.5	4	13	115	140	95	110	50	7.6
25	80	B34	G 3/4"	19	21.8	6	16	195	101	94	7	4	13	100	120	80	110	50	6.9
	90	B34	G 3/4"	24	27.3	8	16	208	101	107	8.5	4	13	115	140	95	110	50	7.8
30	80	B34	G 1"	19	21.8	6	21	249	104.5	144.5	6.5	4	15	100	120	80	120	50	11.4
	90	B34	G 1"	24	27.3	8	21	249	104.5	144.5	9	4	15	115	140	95	120	50	11.4
	100	B34	G 1"	28	31.3	8	21	259	104.5	154.5	9	4	15	130	160	110	120	50	11.9
	112	B34	G 1"	28	31.3	8	21	259	104.5	154.5	9	4	15	130	160	110	120	50	11.9
40	80	B34	G 1"	19	21.8	6	21	258	113.5	144.5	6.5	4	15	100	120	80	120	50	12.1
	90	B34	G 1"	24	27.3	8	21	258	113.5	144.5	9	4	15	115	140	95	120	50	12.1
	100	B34	G 1"	28	31.3	8	21	268	113.5	154.5	9	4	15	130	160	110	120	50	12.6
	112	B34	G 1"	28	31.3	8	21	268	113.5	154.5	9	4	15	130	160	110	120	50	12.6
50	90	B34	G 1 1/4"	24	27.3	8	21	267	122.5	144.5	9	4	15	115	140	95	120	50	12.9
	100	B34	G 1 1/4"	28	31.3	8	21	277	122.5	154.5	9	4	15	130	160	110	120	50	13.4
	112	B34	G 1 1/4"	28	31.3	8	21	277	122.5	154.5	9	4	15	130	160	110	120	50	13.4
60	90	B34	G 1 1/4"	24	27.3	8	21	286	131.5	154.5	9	4	15	115	140	95	120	50	13.5
	100	B34	G 1 1/4"	28	31.3	8	21	286	131.5	154.5	9	4	15	130	160	110	120	50	14
	112	B34	G 1 1/4"	28	31.3	8	21	286	131.5	154.5	9	4	15	130	160	110	120	50	14
70	90	B34	G 1 1/4"	24	27.3	8	21	295	140.5	154.5	9	4	15	115	140	95	120	50	14.3
	100	B34	G 1 1/4"	28	31.3	8	21	295	140.5	154.5	9	4	15	130	160	110	120	50	14.8
	112	B34	G 1 1/4"	28	31.3	8	21	295	140.5	154.5	9	4	15	130	160	110	120	50	14.8
80	90	B34	G 1 1/4"	24	27.3	8	21	304	149.5	154.5	9	4	15	115	140	95	120	50	15
	100	B34	G 1 1/4"	28	31.3	8	21	304	149.5	154.5	9	4	15	130	160	110	120	50	15.5
	112	B34	G 1 1/4"	28	31.3	8	21	304	149.5	154.5	9	4	15	130	160	110	120	50	15.5

Dimensions in mm; tolerances allowed.

3.10.2 APF with IEC electric motor

Fig. 306 - APF dimensional drawing with motor

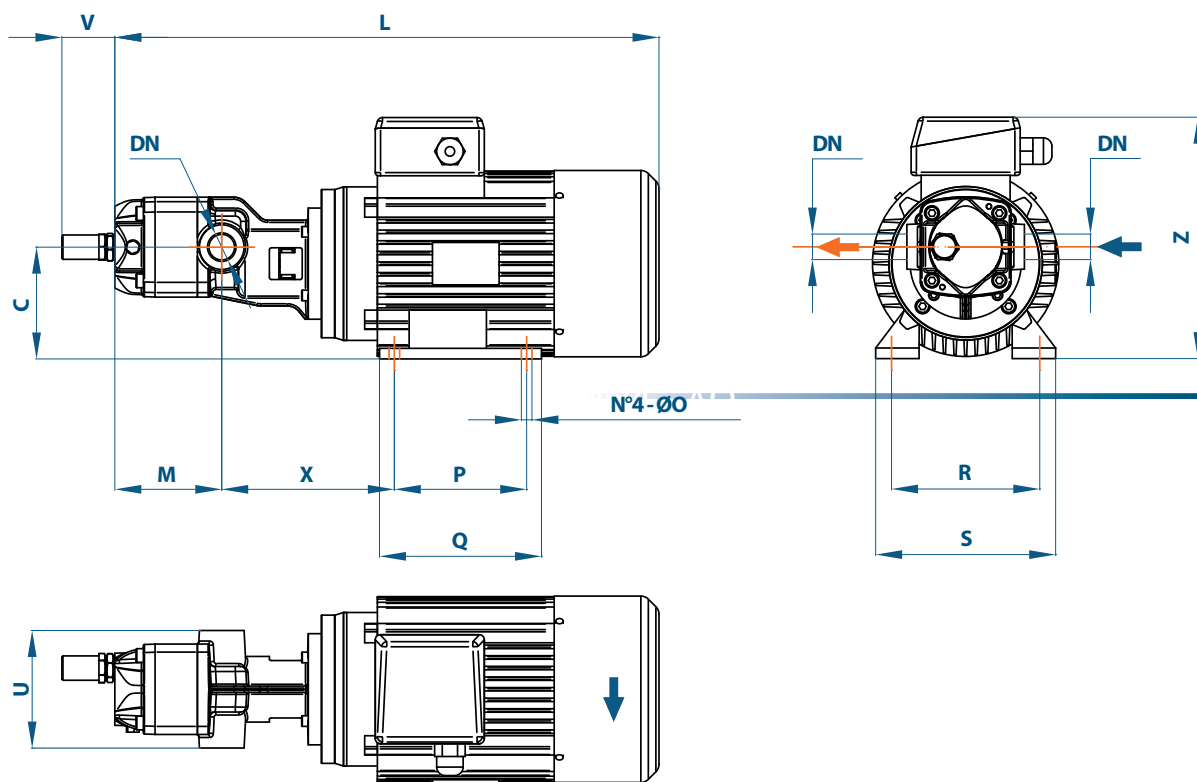

Tab. 306 – APF with motor overall dimensions and weight

PUMP SIZE (APF)	with IEC electric motor		DN ISO 228-1	C	L (*)	M	O	P	Q (*)	R	S (*)	U	V	X	Z (*)	Weight [kg]
	Frame size	IM														
5	71	B34	G 1/2"	87	344	72	10	90	116	112	142	110	50	139	182	11.8
	80	B34	G 1/2"	96	382	72	10	100	130	125	160	110	50	144	200	17.9
10	71	B34	G 3/4"	87	354	82	10	90	116	112	142	110	50	139	182	11.9
	80	B34	G 3/4"	96	392	82	10	100	130	125	160	110	50	144	200	18
15	80	B34	G 3/4"	96	401	91	10	100	130	125	160	110	50	144	200	18.4
	90	B34	G 3/4"	106	447	91	10	125	153	140	170	110	50	163	220	25.8
20	80	B34	G 3/4"	96	406	96	10	100	130	125	160	110	50	144	200	18.6
	90	B34	G 3/4"	106	452	96	10	125	153	140	170	110	50	163	220	26.1
25	80	B34	G 3/4"	96	411	101	10	100	130	125	160	110	50	144	200	18.8
	90	B34	G 3/4"	106	457	101	10	125	153	140	170	110	50	163	220	26.3
30	80	B34	G 1"	101	465	104.5	10	100	130	125	160	120	50	194.5	200	23.3
	90	B34	G 1"	111	498	104.5	10	125	153	140	170	120	50	200.5	220	29.9
	100	B34	G 1"	121	572	104.5	12	140	172	160	200	120	50	217.5	240	36.9
	112	B34	G 1"	133	573	104.5	12	140	174	190	230	120	50	224.5	276	47.4
40	80	B34	G 1"	101	474	113.5	10	100	130	125	160	120	50	194.5	200	24
	90	B34	G 1"	111	507	113.5	10	125	153	140	170	120	50	200.5	220	30.6
	100	B34	G 1"	121	581	113.5	12	140	172	160	200	120	50	217.5	240	37.6
	112	B34	G 1"	133	582	113.5	12	140	174	190	230	120	50	224.5	276	48.1
50	90	B34	G 1 1/4"	111	516	122.5	10	125	153	140	170	120	50	200.5	220	31.4
	100	B34	G 1 1/4"	121	590	122.5	12	140	172	160	200	120	50	217.5	240	38.4
	112	B34	G 1 1/4"	133	591	122.5	12	140	174	190	230	120	50	224.5	276	48.9
60	90	B34	G 1 1/4"	111	535	131.5	10	125	153	140	170	120	50	210.5	220	32
	100	B34	G 1 1/4"	121	599	131.5	12	140	172	160	200	120	50	217.5	240	39
	112	B34	G 1 1/4"	133	600	131.5	12	140	174	190	230	120	50	224.5	276	49.5
70	90	B34	G 1 1/4"	111	544	140.5	10	125	153	140	170	120	50	210.5	220	32.8
	100	B34	G 1 1/4"	121	608	140.5	12	140	172	160	200	120	50	217.5	240	39.8
	112	B34	G 1 1/4"	133	609	140.5	12	140	174	190	230	120	50	224.5	276	50.3
80	90	B34	G 1 1/4"	111	553	149.5	10	125	153	140	170	120	50	210.5	220	33.5
	100	B34	G 1 1/4"	121	617	149.5	12	140	172	160	200	120	50	217.5	240	40.5
	112	B34	G 1 1/4"	133	618	149.5	12	140	174	190	230	120	50	224.5	276	51

Dimensions in mm; tolerances allowed; (*) = depends on the motor manufacturer.

3.11 SPARE PARTS

Fig. 307 – APF pumps (mechanical seal version)

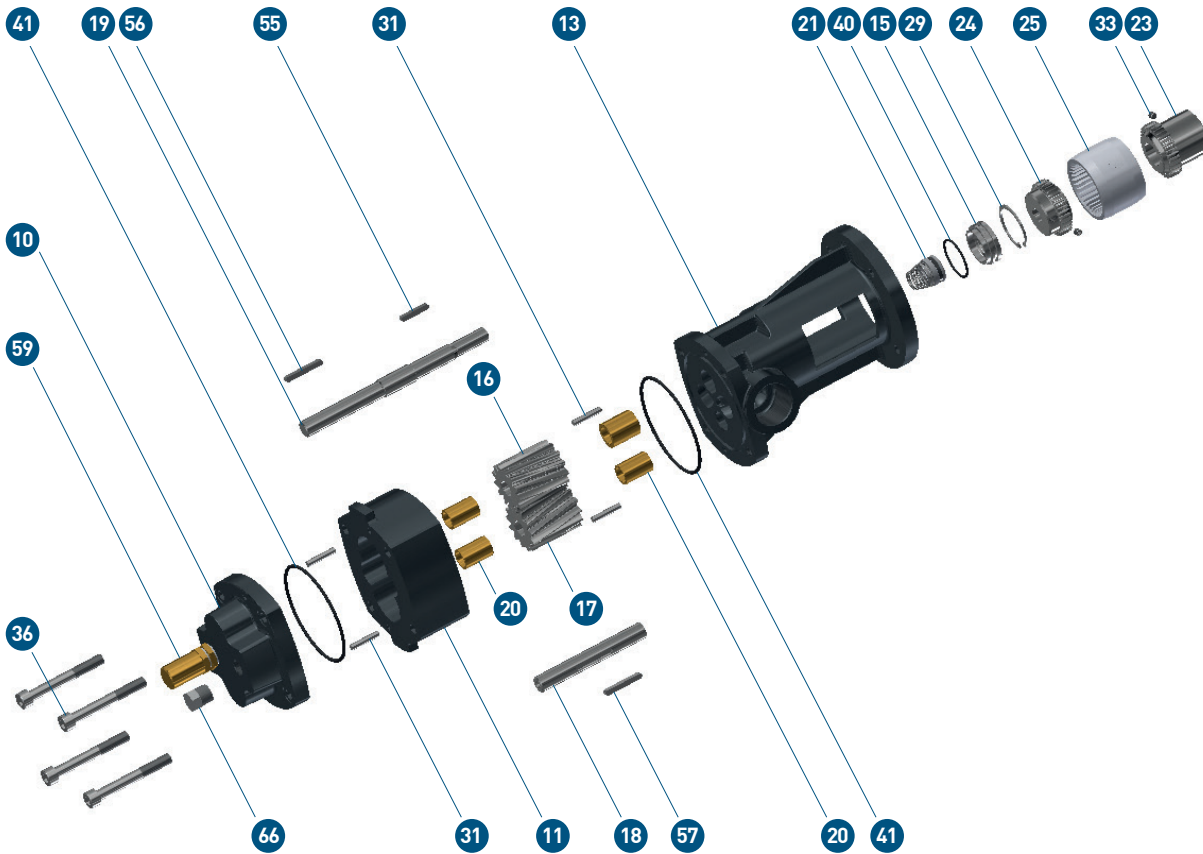

Fig. 308 – Pressure relief valve details

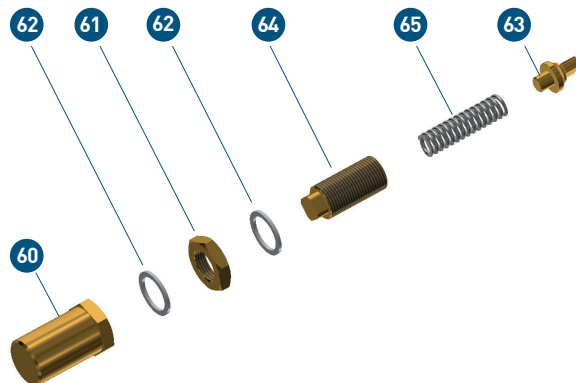
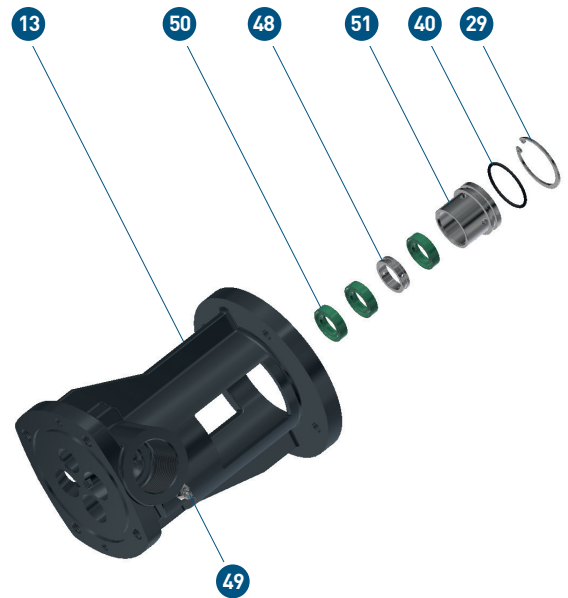

Fig. 309 - Lip seal details



Tab. 307 – APF spare parts list

Ref.	Description	Ref.	Description	Ref.	Description	Ref.	Description
10	Pump rear cover	21	Mechanical seal	41	O-ring	60	Valve cap
11	Pump housing	23	Half-coupling motor side	48	Lantern ring	61	Valve locknut
13	Pump flanged cover	24	Half-coupling pump side	49	Greaser	62	Valve washer
15	Mechanical seal housing	25	Toothed sleeve	50	Lip seals	63	Valve poppet
16	Driving gear	29	Locking ring	51	Lip seal housing	64	Valve adjusting screw
17	Driven gear	31	Dowel pin	55	Feather key	65	Valve spring
18	Driven shaft	33	Grub screw	56	Feather key	66	Threaded cap
19	Driving shaft	36	Screw	57	Feather key		
20	Sleeve bushings	40	O-ring	59	Kit valve		



4+

BMF BCF BFC Series

**Monobloc Gear Pumps,
Bell-Coupling Gear Pumps.**

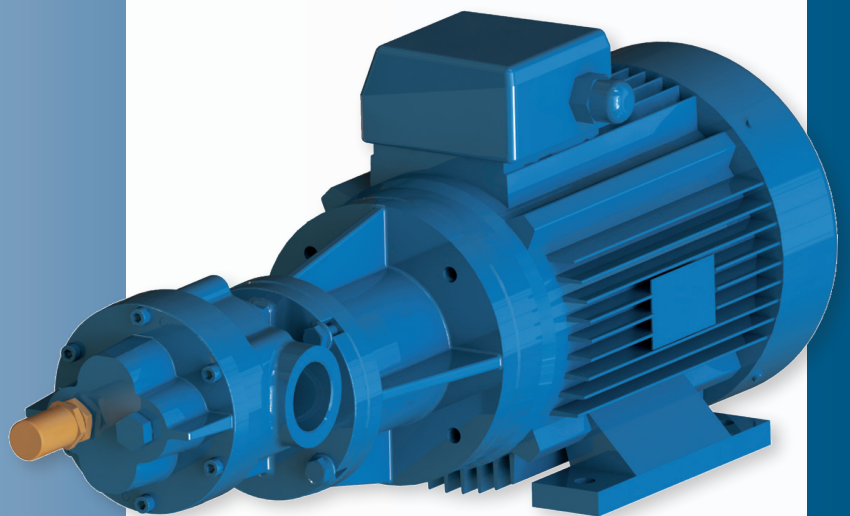

4.1 MAIN CHARACTERISTICS AND NOMINAL FLOW RATES

BMF, BCF and BFC pumps are volumetric gear pumps suitable for transferring lubricant viscous liquids without any suspended solids or abrasive substances. They are self-priming pumps used for a wide range of liquids with a viscosity from 1 to 1.000 cSt. The speed of rotation is chosen according to the viscosity of the liquid. Flowrate range is from 2 to 70 L/min.

The standard construction consists of pump housing and cover in cast iron, shafts and gears in carbon steel, O-rings in Viton, sleeve bushings in Steel-Bronze-PTFE and mechanical seal in ceramic-graphite-Viton. BMF, BCF and BFC pumps are supplied with a pressure relief valve in brass.

Nozzles in inlet and outlet are of the same diameter and

positioned on the same axis.

A short and straight alignment of the flow channels provides for a good suction capability and a quiet running. The helical gears result in extremely low noise levels and reduced pressure pulsation.

BMF (three phase) and BCF (single phase) are monobloc gear pumps with a very compact and strong design. These pumps have an integrated IM B34 electric motor. All the motors are IP55 with an insulation class F. Special voltages and protection IP56/IP65 on request.

The available electric motors are listed in Tables 404, 405, 406.

Fig. 401 – BMF, BCF pumps, standard version

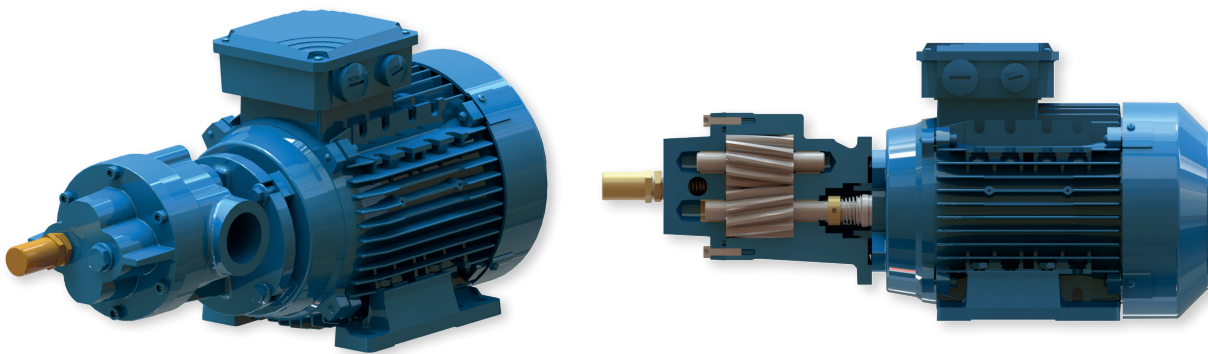

4. BMF, BCF, BFC Series

BFC pumps are designed to fit, by means of a coupling bell and coupling, an industrial electric motor in compliance with the IEC standard with B14 flange and feet (IM B34). The electric motor can be supplied on request.

In table 401 are listed the typical combinations of BFC pumps and B34 electric motors.

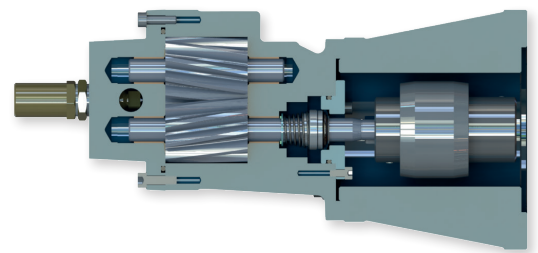
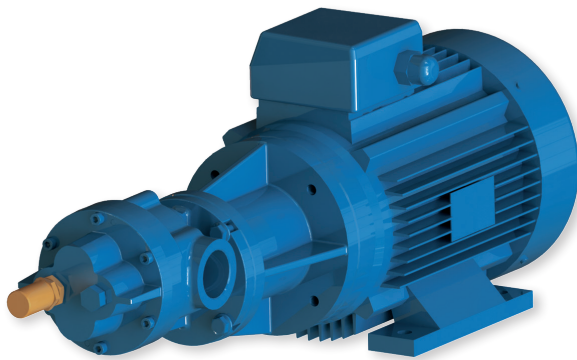

Fig. 402 – BFC pump, standard version

Tab. 401 – B14 flanges available on BFC Series

PUMP SIZE (BFC)	IEC Frame size						
	56	63	71	80	90	100	112
2							
3							
4							
5							
10							
15							
25							
35							
50							
60							
70							

Table 402 shows the possible flow rates for non-pressurized pumping ($\Delta p=0$) and a 46 cSt fluid. The flow rate of gear pumps is virtually proportional to

their speed. The selected speeds are the most common speeds at rated power of industrial electric motors at 50 and 60Hz.

Tab. 402 – Nominal flow rates

PUMP SIZE (BMF, BCF, BFC)	Geometrical displacement V_{geo} [cm ³ /rev]	Nominal flow rate Q_{teq} [L/min] at Speed n [1/min]					
		690	830	950	1150	1400	1750
2	1.5	1.0	1.2	1.4	1.7	2.1	2.6
3	2.1	1.5	1.8	2.0	2.4	3.0	3.7
4	3.0	2.0	2.5	2.8	3.4	4.1	5.2
5	4.6	3.1	3.8	4.3	5.2	6.4	8.0
10	9.1	6.3	7.5	8.6	10.5	12.7	15.9
15	13.6	9.4	11.3	12.9	15.7	19.1	23.9
25	18.2	12.5	15.1	17.3	20.9	25.5	31.8
35	26.7	18.4	22.2	25.4	30.7	37.4	46.7
50	38.0	26.2	31.5	36.1	43.7	53.2	66.5
60	46.3	32.0	38.4	44.0	53.3	64.8	81.1
70	51.0	35.2	42.3	48.4	58.6	71.3	89.2

4.2 MAIN OPTIONS

The main options available are:

- Clockwise rotation (see paragraph 4.3)
- Special seals according to liquids and temperatures (see paragraph 4.4)
- Options on relief valve (see paragraph 4.5)
- Constructions for corrosive liquids and aggressive environments (see paragraph 4.6)
- Motors (see paragraph 4.7)
- Accessories (see paragraph 4.8)
- Heatsink for maximum fluid temperature 300°C available on BFC series

4.3 SENSE OF ROTATION AND FLOW DIRECTION

The standard version of BMF and BCF pumps can operate only in one direction of rotation: counterclockwise watching the electric motor fan.

The direction of rotation of the motor, when properly connected to the mains, is shown by an arrow placed on

the fan cover. Watching the electric motor fan, the flow direction will be from the left side to the right side and the pressure side (delivery) will be at the right-hand side.

On request a clockwise version can be supplied.

Fig. 403 – BMF, BCF Series - Sense of rotation and flow direction

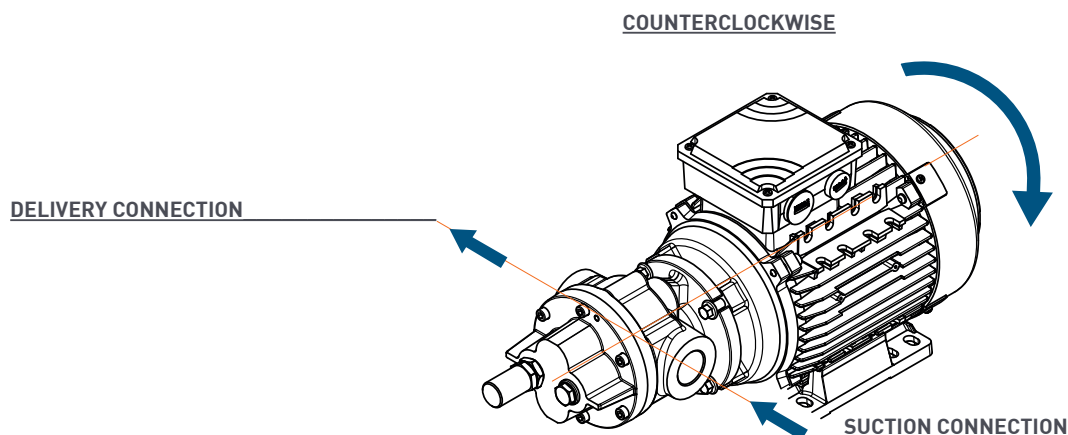

The standard version of BFC pumps, can operate only in one direction of rotation: counterclockwise watching the pump shaft end.

The direction of rotation of the motor, when properly connected to the mains, is shown by an arrow placed on

the fan cover. Watching the electric motor fan, the flow direction will be from the left side to the right side and the pressure side (delivery) will be at the right-hand side.

On request a clockwise version can be supplied.

Fig. 404 – BFC Series - Sense of rotation and flow direction

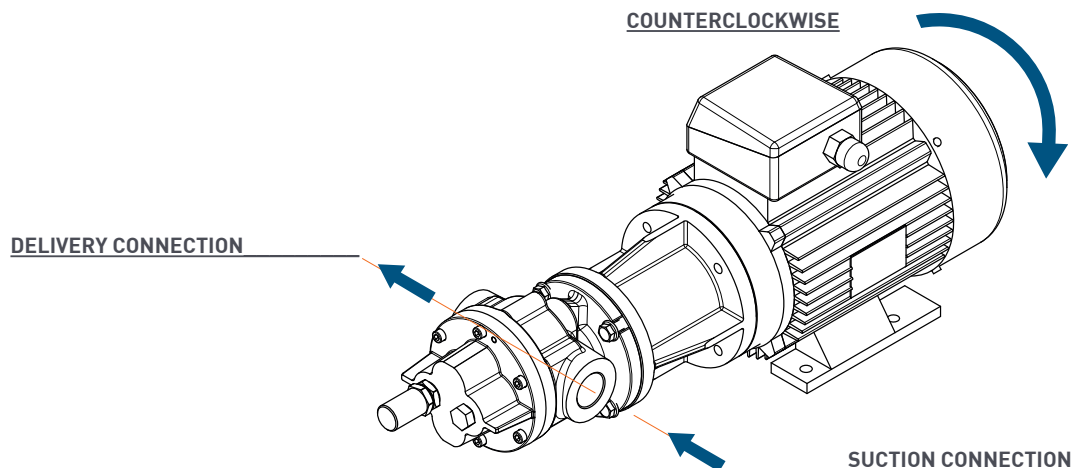

4.4 SHAFT-END SEALS

The standard version is fitted with mechanical seal in ceramic-graphite-FPM. A number of different seals materials can be supplied for different liquids and operating temperatures.

On request:

- Radial lip-type seal in FPM (Viton), NBR or PTFE (Teflon)
- Seal for high temperatures up to 200°C
- Reversible mechanical seal

Fig. 405 – Mechanical seal

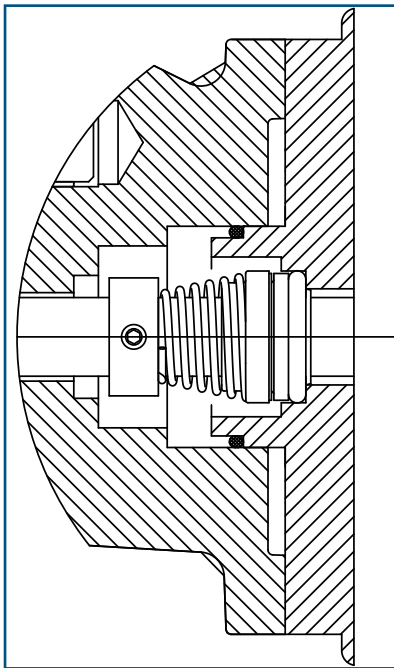
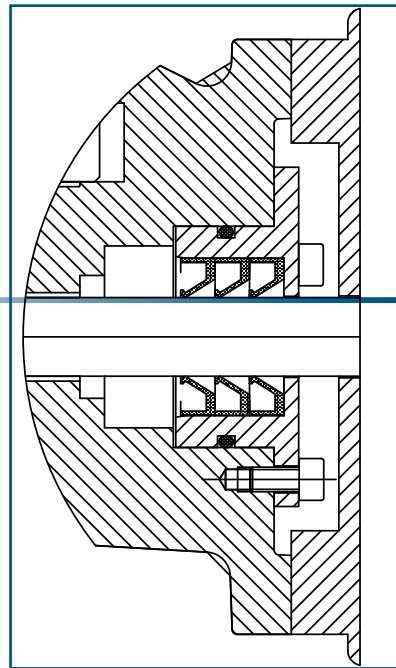

Fig. 406 – Lip seal



4.5 PRESSURE RELIEF VALVE

BMF, BCF, BFC pumps are supplied with a brass pressure relief valve as a standard.

It may be used as a safety valve only for short-term operations. When a partial discharge flow has to be drained over a prolonged period of time, a separate by-pass valve with return to the suction tank has to be installed into the piping.

The pressure relief valve is designed as a spring-preloaded piston valve. It is integrated into the pump's end cover.

The spring pretension and the relative opening pressure can be adjusted by means of a screw. Different springs are

also available to reach the desired adjustment range. The pressure relief valve is available on request in stainless steel construction.

There is the possibility of mounting a double relief valve: when it is necessary to have a reversible pump that works both in inlet and outlet. In this case it is compulsory to mount a reversible mechanical seal.

The relief valve holes and circuit, can be used as a heating solution when needed. In this case it is not possible to mount the relief valve.

As an option the pumps can be supplied without relief valve.

4.6 VERSION FOR AGGRESSIVE LIQUIDS AND ENVIRONMENTS

BMF, BCF, BFC pumps can be supplied in a corrosion and acid-resistant construction.

Stainless-steel version

Pump housing, cover, shafts and gears in stainless steel and sleeve bushings in AISI 316-Bronze-PTFE.

Bronze version

Pump housing and cover in bronze, shaft and gears in stainless

steel, and sleeve bushings in AISI 316-Bronze-PTFE.

Seals and gaskets materials are chosen according to the liquid pumped.

Many combinations suitable for corrosive liquids and aggressive environment can be supplied as follows:

- Gears in bronze
- Sleeve bushings in PTFE or Tecapeek on BFC series

4.7 MOTORIZATION

The most common installed electric motors have the following characteristics:

- Standard motors for BMF, BCF serie in IP55, insulation class F available at 4 and 6 poles
- Standard motors for BFC serie in IP55, insulation class F available at 4, 6 and 8 poles
- Standard voltages for Three-phase motors $\leq 4\text{kW}$ 230/400V 50Hz - 265/460V 60Hz
- Standard voltages for Single-phase motors 230V 50Hz.

Special options on electric motors:

- Motors with built-in frequency converter (only for BFC serie)
- Motors suitable for frequency converter connection
- Motor with forced ventilation (only for BFC serie)
- Tropicalization

- Special voltages
- Protection IP56/IP65
- Protection IP67/IP68 (only for BFC serie)
- Thermistors PTC
- Special treatment for corrosive and saline environment
- Motors according to UL-CSA, NEMA, cURus and Marine regulations
- Insulation class H
- Motor form B35 (only for BFC serie)

Special motors only for BFC serie:

- Internal combustion engines
- Gearmotor
- Mechanical variator
- DC motors at 12V and 24V

4.8 ACCESSORIES

- Pump on trolley
- Control panel
- ON/OFF switches
- Reversing switches
- Piping
- Heated piping
- Valves
- Pressure gauge and pressure switch
- Electric cables

4.9 PUMP SELECTION AND PERFORMANCE DATA

In table 403 are listed the actual delivery Q_{eff} and required power P_{mec} for each pump size at different speeds and pressures.

The data refers to a mineral oil ISO46 (Kinematic viscosity 46 cSt at 40°C).

The rated power for the drive motor should be 20% higher than the required power P_{mec} .

For different viscosities please ask the performances (delivery and power) to our Technical department.

As a general rule the flow rate is approximately proportional to the speed.

A lower viscosity may lead to a loss of the net delivery and a higher viscosity may lead to an increase of the net delivery.

When dimensioning please consider the maximum viscosity, usually at the start-up phase.

Pump selection, delivery and required power at different speeds:

- 1) Given the project delivery Q_{pro} [L/min] and speed n_{pro} [1/min] calculate the project displacement V_{pro} [cm³/rev]:

$$V_{\text{pro}} = 1000 \times Q_{\text{pro}} / n_{\text{pro}}$$

- 2) Select the Pump Type with the geometrical displacement V_{geo} closer to V_{pro} ,

- 3) Read from the Performance Table the delivery at 1450 1/min and at the given pressure p:

$$Q_{1450, p} \text{ [L/min]}$$

- 4) Calculate the actual delivery Q [L/min] at n_{pro} and p:

$$Q = Q_{1450, p} + V_{\text{geo}} \times (n_{\text{pro}} - 1450) / 1000$$

- 5) Read from the Performance Table the required power and actual delivery of the selected Pump Type at the closer speed n_x to n_{pro} and at p:

$$P_{n_x, p} \text{ [kW]}, Q_{n_x, p} \text{ [L/min]}$$

- 6) Calculate the actual required power P at n_{pro} and p [kW]:

$$P = P_{n_x, p} \times Q / Q_{n_x, p}$$

Tab. 403 - Performance data at 690, 830, 950, 1150, 1450, 1750 1/min and 46 cSt

PUMP SIZE (BMF, BCF, BFC)	Geometrical displacement V_{geo} [cm ³ /rev]	Pressure P [bar]	Speed n [1/min]											
			690		830		950		1150		1450		1750	
			Q_{eff} [L/min]	P_{mec} [kW]	Q_{eff} [L/min]	P_{mec} [kW]	Q_{eff} [L/min]	P_{mec} [kW]	Q_{eff} [L/min]	P_{mec} [kW]	Q_{eff} [L/min]	P_{mec} [kW]	Q_{eff} [L/min]	P_{mec} [kW]
2	1.5	2	1.0	0.02	1.2	0.02	1.3	0.03	1.6	0.03	2.0	0.04	2.5	0.05
		5	0.9	0.04	1.0	0.05	1.2	0.05	1.5	0.06	1.9	0.08	2.3	0.10
		10	0.7	0.08	0.8	0.09	1.0	0.10	1.2	0.12	1.6	0.14	2.0	0.18
		12	0.6	0.09	0.8	0.11	0.9	0.12	1.2	0.14	1.5	0.16	1.9	0.21
3	2.1	2	1.4	0.02	1.7	0.03	1.9	0.03	2.3	0.04	2.9	0.05	3.6	0.07
		5	1.2	0.05	1.5	0.06	1.8	0.07	2.2	0.08	2.8	0.11	3.4	0.13
		10	1.0	0.10	1.3	0.11	1.5	0.13	1.9	0.16	2.5	0.19	3.1	0.22
		12	1.0	0.11	1.2	0.14	1.4	0.15	1.8	0.18	2.3	0.22	2.9	0.26
4	3.0	2	2.0	0.02	2.4	0.03	2.7	0.03	3.3	0.04	4.2	0.06	5.0	0.07
		5	1.8	0.05	2.2	0.06	2.5	0.07	3.1	0.09	4.0	0.11	4.8	0.14
		10	1.6	0.11	1.9	0.13	2.3	0.14	2.8	0.17	3.6	0.21	4.5	0.25
		12	1.5	0.13	1.8	0.15	2.2	0.17	2.7	0.20	3.5	0.25	4.3	0.29
5	4.6	2	3.0	0.03	3.7	0.04	4.2	0.05	5.1	0.06	6.4	0.08	6.4	0.08
		5	2.9	0.08	3.5	0.09	4.0	0.11	4.9	0.13	6.2	0.17	6.2	0.17
		10	2.6	0.2	3.2	0.19	3.7	0.21	4.5	0.26	5.8	0.32	5.8	0.32
		12	2.5	0.2	3.1	0.22	3.5	0.26	4.4	0.31	5.6	0.38	5.6	0.38
10	9.1	2	6.1	0.05	7.3	0.06	8.4	0.07	10.2	0.08	12.9	0.11	15.6	0.14
		5	5.8	0.11	7.0	0.14	8.0	0.16	9.8	0.2	12.4	0.2	15.1	0.3
		10	5.3	0.2	6.5	0.3	7.4	0.3	9.1	0.4	11.6	0.5	14.2	0.6
		12	5.1	0.3	6.2	0.3	7.2	0.4	8.8	0.5	11.3	0.6	13.8	0.7
15	13.6	2	8.9	0.1	10.8	0.1	12.3	0.1	15.0	0.1	19.0	0.2	23.0	0.2
		5	8.2	0.2	9.9	0.2	11.4	0.3	14.0	0.3	17.8	0.4	21.7	0.5
		10	6.9	0.4	8.5	0.4	9.9	0.5	12.3	0.6	15.9	0.7	19.6	0.9
		12	6.4	0.4	8.0	0.5	9.3	0.6	11.6	0.7	15.1	0.9	18.8	1.0
25	18.2	2	11.9	0.1	14.4	0.1	16.5	0.1	20.1	0.1	25.5	0.2	30.9	0.2
		5	10.9	0.2	13.3	0.2	15.3	0.3	18.8	0.3	24.1	0.4	29.5	0.5
		10	9.2	0.3	11.5	0.4	13.4	0.5	16.8	0.6	21.9	0.8	27.2	1.0
		12	8.6	0.4	10.7	0.5	12.6	0.6	15.9	0.7	21.0	0.9	26.3	1.1
35	26.7	2	18.0	0.1	21.6	0.1	24.8	0.2	30.1	0.2	38.0	0.3	45.9	0.4
		5	17.3	0.3	20.9	0.3	24.0	0.4	29.1	0.5	36.9	0.6	44.7	0.8
		10	16.2	0.6	19.6	0.7	22.6	0.8	27.6	0.9	35.1	1.2	42.7	1.4
		12	15.7	0.7	19.1	0.8	22.0	0.9	26.9	1.1	34.4	1.4	41.9	1.7
50	38.0	2	25.5	0.2	30.8	0.2	35.4	0.3	43.0	0.3	54.5	0.5	65.8	0.6
		5	24.4	0.4	29.7	0.5	34.3	0.6	42.0	0.7	53.5	0.9	64.7	1.1
		10	22.7	0.7	27.9	0.9	32.5	1.0	40.2	1.3	51.9	1.6	62.9	2.0
		12	22.0	0.9	27.2	1.1	31.8	1.2	39.5	1.5	51.3	1.9	62.2	2.3
60	46.3	2	31.2	0.3	37.6	0.3	43.2	0.4	52.4	0.5	66.5	0.7	80.3	0.9
		5	30.1	0.6	36.4	0.7	41.9	0.8	51.1	1.0	65.5	1.3	79.1	1.7
		10	28.2	1.2	34.4	1.4	39.8	1.5	48.9	1.8	63.9	2.3	77.2	2.9
		12	27.5	1.4	33.6	1.6	39.0	1.8	48.1	2.1	63.2	2.7	76.5	3.4
70	51.0	2	33.6	0.2	40.5	0.3	46.5	0.3	56.5	0.4	71.6	0.6	86.6	0.7
		5	31.9	0.5	38.7	0.6	44.6	0.7	54.5	0.9	69.5	1.1	84.6	1.4
		10	29.2	1.0	35.7	1.2	41.5	1.3	51.2	1.6	66.0	2.1	81.1	2.5
		12	28.0	1.1	34.5	1.4	40.2	1.6	49.9	1.9	64.6	2.5	79.8	3.0

Different viscosities, working pressure, rotational speed and ambient conditions can change performance data shown in the table.

4.10 INTEGRATED ELECTRIC MOTORS AVAILABLE ON PUMPS BMF AND BCF

Tab. 404 - Rated Data for integrated electric motors available on pumps BMF – Three-phase 400V / 50Hz

Pole	Frame Size	Power [kW]	IE	Speed [1/min]	Current [A]	Available on Pump BMF Size	
4	63	0.13	1	1360	0,50		
	63	0.18	1	1325	0,70	2	3
	63	0.25	1	1360	0,90		4
	71	0.37	1	1380	1,00		5
	71	0.55	1	1395	1,55		10
	80	0.75	3	1425	1,70		15
	90	1.10	3	1440	2,50		25
	90	1.50	3	1430	3,60		35
	90	1.80	3	1420	4,30		50
6	71	0.18	1	880	0,90		
	71	0.26	1	870	1,20		5
	80	0.37	1	910	1,25		10
	80	0.55	1	920	1,57		15
	90	0.75	3	935	2,00		25
	90	1.10	3	935	3,10		35
							50
						60	
						70	

(*) Mechanically different motors.

Tab. 405 - Rated Data for integrated electric motors available on pumps BCF – Single-phase 230V / 50Hz

Pole	Frame Size	Power [kW]	IE	Speed [1/min]	Current [A]	Available on Pump BCF Size	
4	63	0.11	1	1400	1.20		
	63	0.18	1	1350	1.70	2	3
	71	0.29	1	1300	2.40		4
	71	0.37	1	1370	3.20		5
	80	0.55	1	1390	4.20		10
	80	0.75	1	1445	5.10		15
	90	1.10	1	1430	7.30		25
	90	1.50	1	1430	9.30		35
6	71	0.18	1	870	1.80		
	80	0.25	1	900	2.40		5
	80	0.37	1	940	3.00		10
	90	0.55	1	950	3.60		15
						25	

(*) Mechanically different motors.

Tab. 406 - Rated Data for integrated electric motors available on pumps BMF – Three-phase 460V / 60Hz

Pole	Frame Size	Power [kW]	IE	Speed [1/min]	Current [A]	Available on Pump BMF Size	
4	63	0.15	1	1630	0.50	2	3
	63	0.22	1	1590	0.70	4	
	63	0.30	1	1630	0.90		5 (*)
	71	0.37	1	1700	0.88		10
	71	0.55	1	1715	1.40		15
	80	0.75	3	1735	1.50		25 (*)
	90	1.10	2	1745	2.30		35
	90	1.50	2	1740	3.30		50
	90	1.80	2	1730	4.10		60
							70
6	71	0.22	1	1060	0.90		5
	71	0.30	1	1040	1.20		10
	80	0.44	1	1090	1.25		15
	80	0.55	1	1135	1.44		25
	90	0.75	3	1150	1.75		35 (*)
	90	1.10	1	1130	2.70		50
							60
							70

(*) Mechanically different motors.

4.11 SOUND LEVEL

The sound level has been measured in dB(A) at 1m distance, at 1450 1/min with gear oil (viscosity 46 cSt).

Tab. 407- Sound level

PUMP SIZE (BMF, BCF, BFC)	Sound level dB(A) at pressure			
	2 bar	5 bar	10 bar	12 bar
2	64	64	64	65
3	64	64	64	65
4	64	64	64	65
5	71	72	72.5	72.5
10	71	72	72.5	72.5
15	71	72	72.5	72.5
25	71	72	72.5	72.5
35	72	72	74	74
50	72	72	74	74
60	72	72	74	74
70	72	72	74	74

4.12 OVERALL DIMENSIONS AND WEIGHTS

4.12.1 BMF, BCF

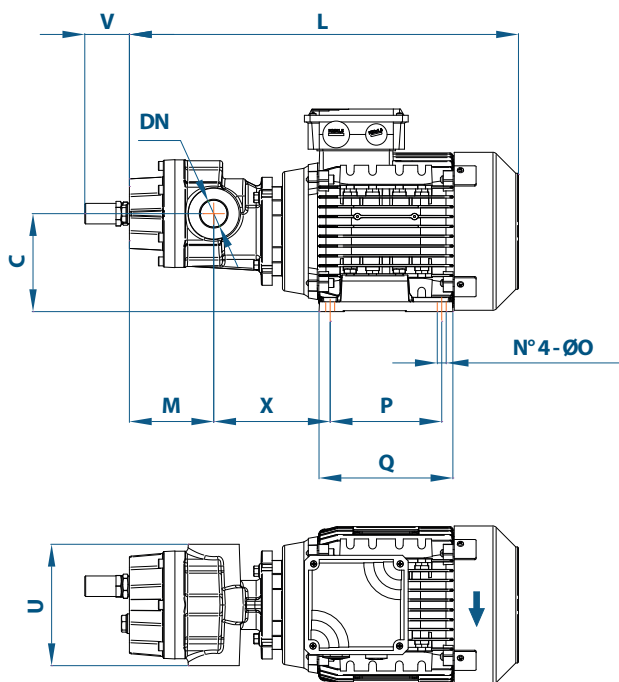
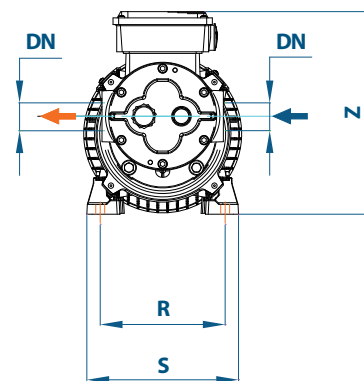

Fig. 407 - BMF, BCF dimensional drawing



Tab. 408 - BMF, BCF overall dimensions and weights

PUMP SIZE (BMF, BCF)	with IEC electric motor		DN ISO 228-1	C	L (*)	M	O	P	Q (*)	R	S (*)	U	V	X	Z (*)	Weight [kg]
	Frame size	IM														
2	63	B34	G 3/8"	74	266	49	7	80	100	100	120	85	50	69.5	165	6.2
3	63	B34	G 3/8"	74	268.5	52	7	80	100	100	120	85	50	69.5	165	6.3
4	63	B34	G 3/8"	74	272.5	56	7	80	100	100	120	85	50	69.5	165	6.5
5	63	B34	G 1/2"	78.5	298	61	7	80	100	100	120	113	50	90	165	8
	71	B34	G 1/2"	86.5	326	61	8	90	116	112	142	113	50	95	182	9.8
10	63	B34	G 3/4"	78.5	318	66	7	80	100	100	120	113	50	105	165	8.6
	71	B34	G 3/4"	86.5	346	66	8	90	116	112	142	113	50	110	182	10.4
	80	B34	G 3/4"	95.5	397	66	10	100	130	125	160	113	50	115	200	13.7
15	71	B34	G 3/4"	86.5	356	76	8	90	116	112	142	113	50	110	182	11
	80	B34	G 3/4"	95.5	407	76	10	100	130	125	160	113	50	115	200	14.3
	90	B34	G 3/4"	105.5	447	76	10	125	153	140	170	113	50	121	238	20
25	71	B34	G 3/4"	91	366	85.5	8	90	116	112	142	113	50	110.5	182	11.5
	80	B34	G 3/4"	100	417	85.5	10	100	130	125	160	113	50	115.5	200	14.8
	90	B34	G 3/4"	110	457	85.5	10	125	153	140	170	113	50	121.5	238	20.5
35	80	B34	G 1"	100	427	95.5	10	100	130	125	160	136	50	115.5	200	16.7
	90	B34	G 1"	110	467	95.5	10	125	153	140	170	136	50	121.5	238	22.4
50	90	B34	G 1"	110	466	94.5	10	125	153	140	170	136	50	121.5	238	22.6
60	90	B34	G 1 1/4"	110	476	104.5	10	125	153	140	170	136	50	121.5	238	22.8
70	90	B34	G 1 1/4"	110	476	104.5	10	125	153	140	170	136	50	121.5	238	23

Dimensions in mm; tolerances allowed; (*) = depends on the motor manufacturer.

4.12.2 BFC

Fig. 408 - BFC dimensional drawing

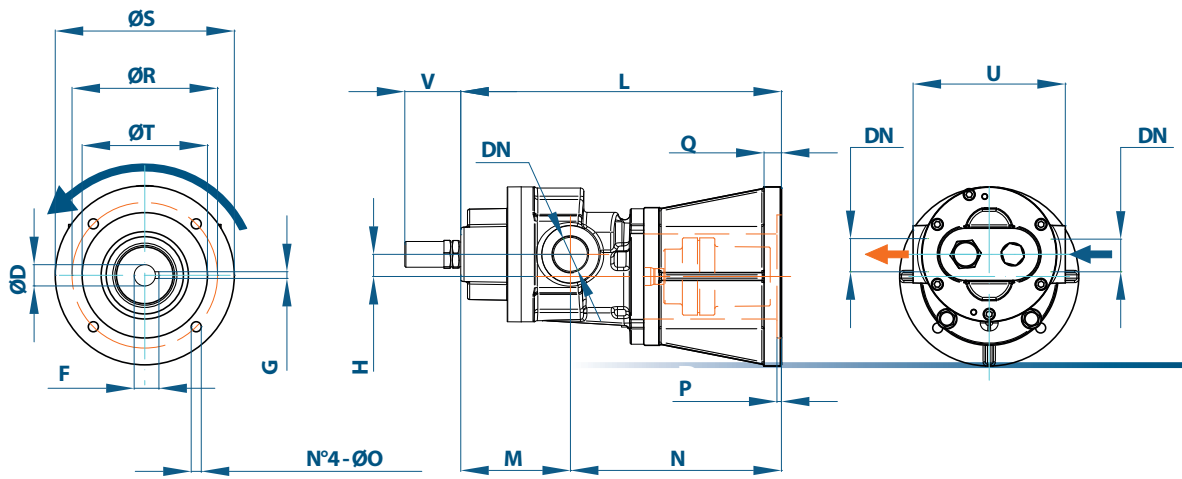

Tab. 409 - BFC overall dimensions and weights

PUMP SIZE (BFC)	for IEC electric motor		DN ISO 228-1	D	F	G	H	L	M	N	O	P	Q	R	S	T	U	V	Weight [kg]
	Frame size	IM																	
	2	56	B34	G 3/8"	11	12.8	4	11	155.5	49	106.5	5.5	4	8	65	80	50	85	50
63		B34	G 3/8"	11	12.8	4	11	155.5	49	106.5	5.5	4	8	75	90	60	85	50	2.6
71		B34	G 3/8"	11	12.8	4	11	163.5	49	114.5	5.5	4	8	85	105	70	85	50	2.6
3	56	B34	G 3/8"	11	12.8	4	11	158.5	52	106.5	5.5	4	8	65	80	50	85	50	2.7
	63	B34	G 3/8"	11	12.8	4	11	158.5	52	106.5	5.5	4	8	75	90	60	85	50	2.7
	71	B34	G 3/8"	11	12.8	4	11	166.5	52	114.5	5.5	4	8	85	105	70	85	50	2.7
4	56	B34	G 3/8"	11	12.8	4	11	162.5	56	106.5	5.5	4	8	65	80	50	85	50	2.8
	63	B34	G 3/8"	11	12.8	4	11	162.5	56	106.5	5.5	4	8	75	90	60	85	50	2.8
	71	B34	G 3/8"	11	12.8	4	11	170.5	56	114.5	5.5	4	8	85	105	70	85	50	2.8
5	71	B34	G 1/2"	14	16.3	5	15.5	234	61	173	6.5	4	15.5	85	105	70	113	50	5.5
	80	B34	G 1/2"	14	16.3	5	15.5	234	61	173	6.5	4	15.5	100	120	80	113	50	5.5
10	71	B34	G 3/4"	14	16.3	5	15.5	254	66	188	6.5	4	15.5	85	105	70	113	50	6.3
	80	B34	G 3/4"	19	21.8	6	15.5	254	66	188	6.5	4	15.5	100	120	80	113	50	6.3
15	71	B34	G 3/4"	14	16.3	5	15.5	264	76	188	6.5	4	15.5	85	105	70	113	50	6.8
	80	B34	G 3/4"	19	21.8	6	15.5	264	76	188	6.5	4	15.5	100	120	80	113	50	6.8
25	71	B34	G 3/4"	19	21.8	6	15.5	274	85.5	188.5	6.5	4	15.5	100	120	80	113	50	7.3
	80	B34	G 3/4"	19	21.8	6	15.5	274	85.5	188.5	6.5	4	15.5	100	120	80	113	50	7.3
	90	B34	G 3/4"	24	27.3	8	15.5	274	85.5	188.5	9	4	15.5	115	140	95	113	50	7.6
35	80	B34	G 1"	19	21.8	6	20	284	95.5	188.5	6.5	4	15.5	100	120	80	136	50	9.4
	90	B34	G 1"	24	27.3	8	20	284	95.5	188.5	9	4	15.5	115	140	95	136	50	9.6
	100	B34	G 1"	24	27.3	8	20	284	95.5	188.5	9	4	15.5	130	160	110	136	50	9.6
	112	B34	G 1"	24	27.3	8	20	284	95.5	188.5	9	4	15.5	130	160	110	136	50	9.6
50	90	B34	G 1"	24	27.3	8	20	283	94.5	188.5	9	4	15.5	115	140	95	136	50	9.7
	100	B34	G 1"	24	27.3	8	20	283	94.5	188.5	9	4	15.5	130	160	110	136	50	9.7
	112	B34	G 1"	24	27.3	8	20	283	94.5	188.5	9	4	15.5	130	160	110	136	50	9.7
60	90	B34	G 1 1/4"	24	27.3	8	20	293	104.5	188.5	9	4	15.5	115	140	95	136	50	10.2
	100	B34	G 1 1/4"	24	27.3	8	20	293	104.5	188.5	9	4	15.5	130	160	110	136	50	10.2
	112	B34	G 1 1/4"	24	27.3	8	20	293	104.5	188.5	9	4	15.5	130	160	110	136	50	10.2
70	90	B34	G 1 1/4"	24	27.3	8	20	293	104.5	188.5	9	4	15.5	115	140	95	136	50	10.3
	100	B34	G 1 1/4"	24	27.3	8	20	293	104.5	188.5	9	4	15.5	130	160	110	136	50	10.3
	112	B34	G 1 1/4"	24	27.3	8	20	293	104.5	188.5	9	4	15.5	130	160	110	136	50	10.3

Dimensions in mm; tolerances allowed.

4.12.3 BFC with IEC electric motor

Fig. 409 - BFC dimensional drawing with motor

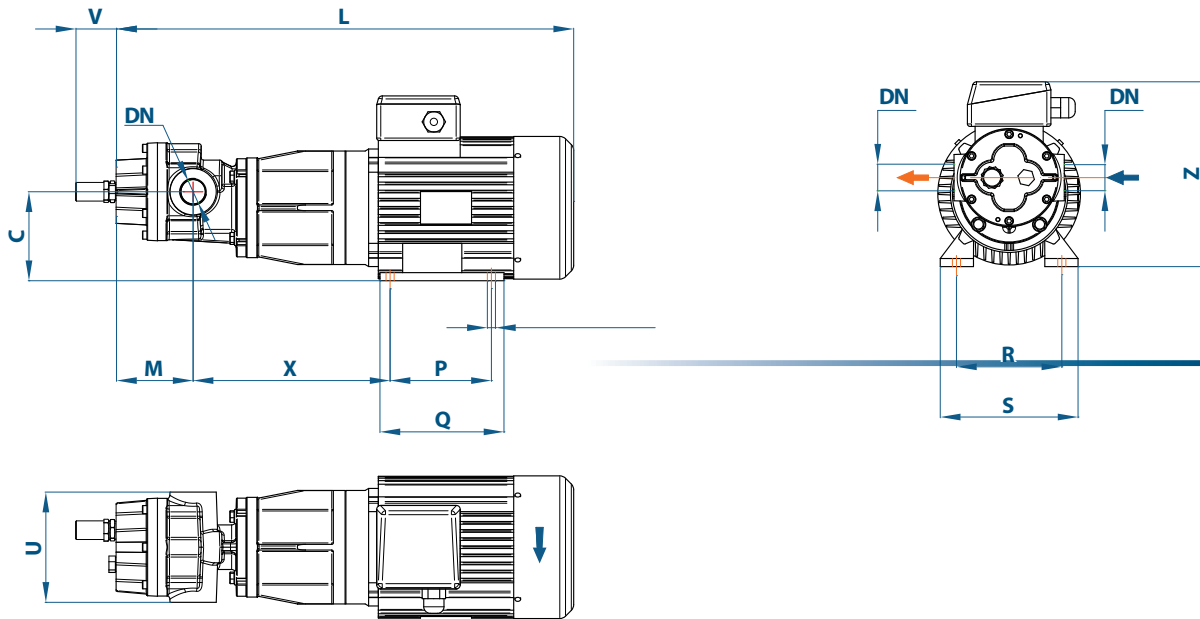

Tab. 410 - BFC with motor overall dimensions and weights

PUMP SIZE (BFC)	with IEC electric motor		DN	C	L (*)	M	O	P	Q (*)	R	S (*)	U	V	X	Z (*)	Weight [kg]
	Frame size	IM	ISO 228-1													
2	63	B34	G 3/8"	74	342.5	49	7	80	100	100	120	85	50	146.5	165	6.8
	71	B34	G 3/8"	82	378.5	49	8	90	116	112	142	85	50	159.5	182	8.6
3	63	B34	G 3/8"	74	345.5	52	7	80	100	100	120	85	50	146.5	165	6.9
	71	B34	G 3/8"	82	381.5	52	8	90	116	112	142	85	50	159.5	182	8.7
4	63	B34	G 3/8"	74	349.5	56	7	80	100	100	120	85	50	146.5	165	7
	71	B34	G 3/8"	82	377.5	56	8	90	116	112	142	85	50	151.5	182	8.8
5	71	B34	G 1/2"	86.5	449	61	8	90	116	112	142	113	50	218	182	11.5
	80	B34	G 1/2"	95.5	500	61	10	100	130	125	160	113	50	223	200	14.8
10	71	B34	G 3/4"	86.5	469	66	8	90	116	112	142	113	50	233	182	12.3
	80	B34	G 3/4"	95.5	520	66	10	100	130	125	160	113	50	238	200	15.6
15	71	B34	G 3/4"	86.5	479	76	8	90	116	112	142	113	50	233	182	12.8
	80	B34	G 3/4"	95.5	530	76	10	100	130	125	160	113	50	238	200	16.1
	90	B34	G 3/4"	105.5	570	76	10	125	153	140	170	113	50	244	238	21.8
25	71	B34	G 3/4"	86.5	489	85.5	8	90	116	112	142	113	50	233.5	182	13.3
	80	B34	G 3/4"	95.5	540	85.5	10	100	130	125	160	113	50	238.5	200	16.6
	90	B34	G 3/4"	105.5	580	85.5	10	125	153	140	170	113	50	244.5	238	22.6
35	80	B34	G 1"	100	550	95.5	10	100	130	125	160	136	50	238.5	200	18.7
	90	B34	G 1"	110	590	95.5	10	125	153	140	170	136	50	244.5	238	24.6
	100	B34	G 1"	120	641	95.5	12	140	170	160	202	136	50	251.5	257	40.6
50	90	B34	G 1"	110	589	94.5	10	125	153	140	170	136	50	244.5	238	24.7
	100	B34	G 1"	120	640	94.5	12	140	170	160	202	136	50	251.5	257	40.7
60	90	B34	G 1 1/4"	110	599	104.5	10	125	153	140	170	136	50	244.5	238	25.2
	100	B34	G 1 1/4"	120	650	104.5	12	140	170	160	202	136	50	251.5	257	41.2
	112	B34	G 1 1/4"	132	658	104.5	12	140	170	190	222	136	50	258.5	280	51.7
70	90	B34	G 1 1/4"	110	599	104.5	10	125	153	140	170	136	50	244.5	238	25.3
	100	B34	G 1 1/4"	120	650	104.5	12	140	170	160	202	136	50	251.5	257	41.3
	112	B34	G 1 1/4"	132	658	104.5	12	140	170	190	222	136	50	258.5	280	51.8

Dimensions in mm; tolerances allowed; (*) = depends on the motor manufacturer.

4.13 SPARE PARTS

Fig. 410 – BMF, BCF pumps (mechanical seal version)

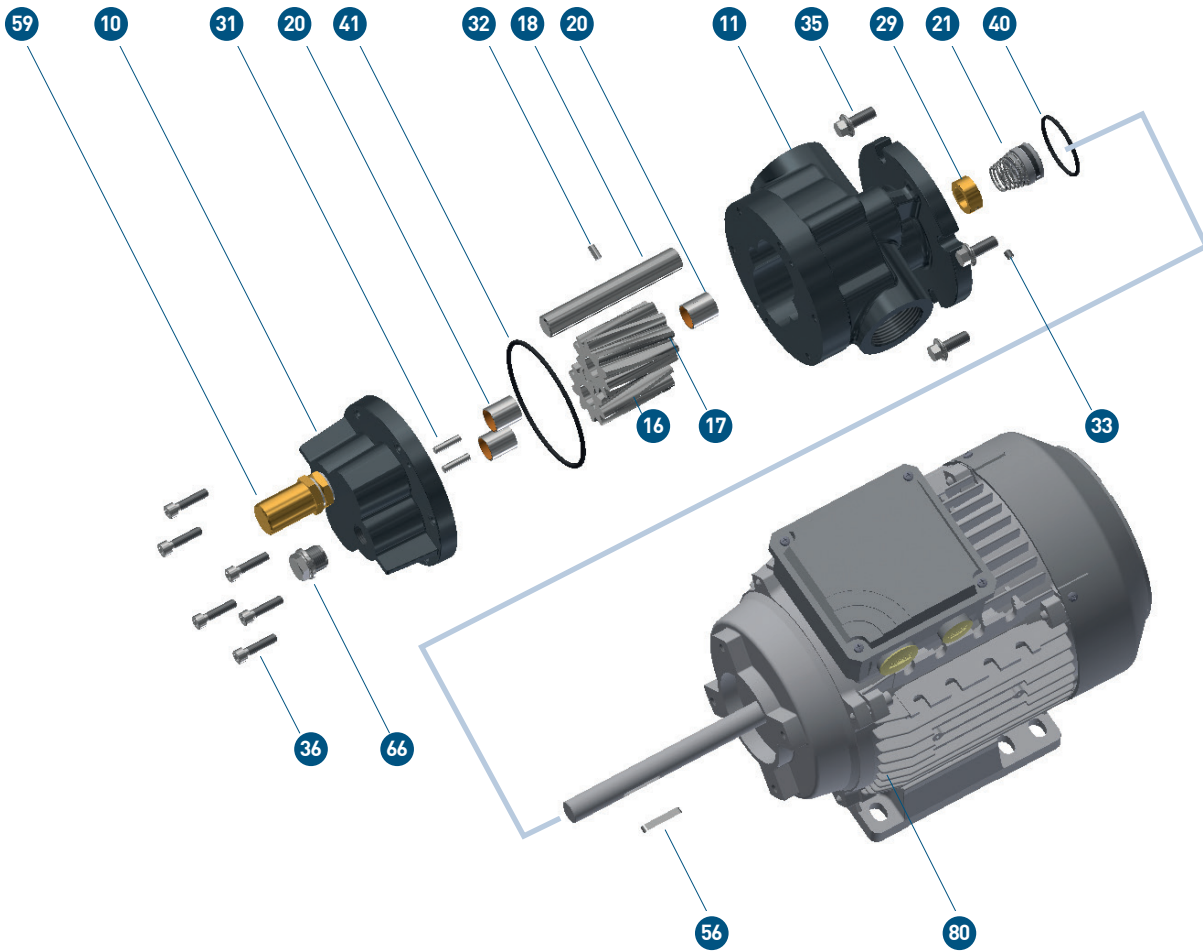

Fig. 308 – Pressure relief valve details

Fig. 411 – Lip seal details

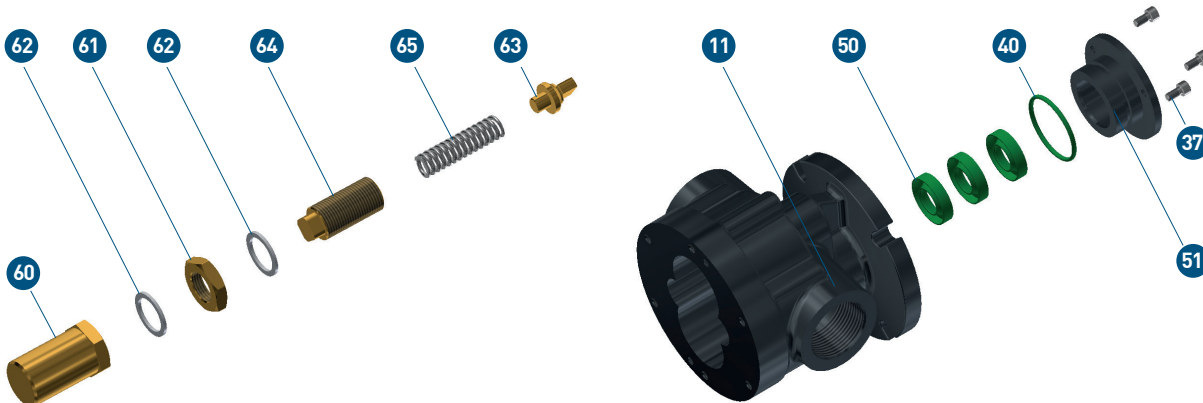
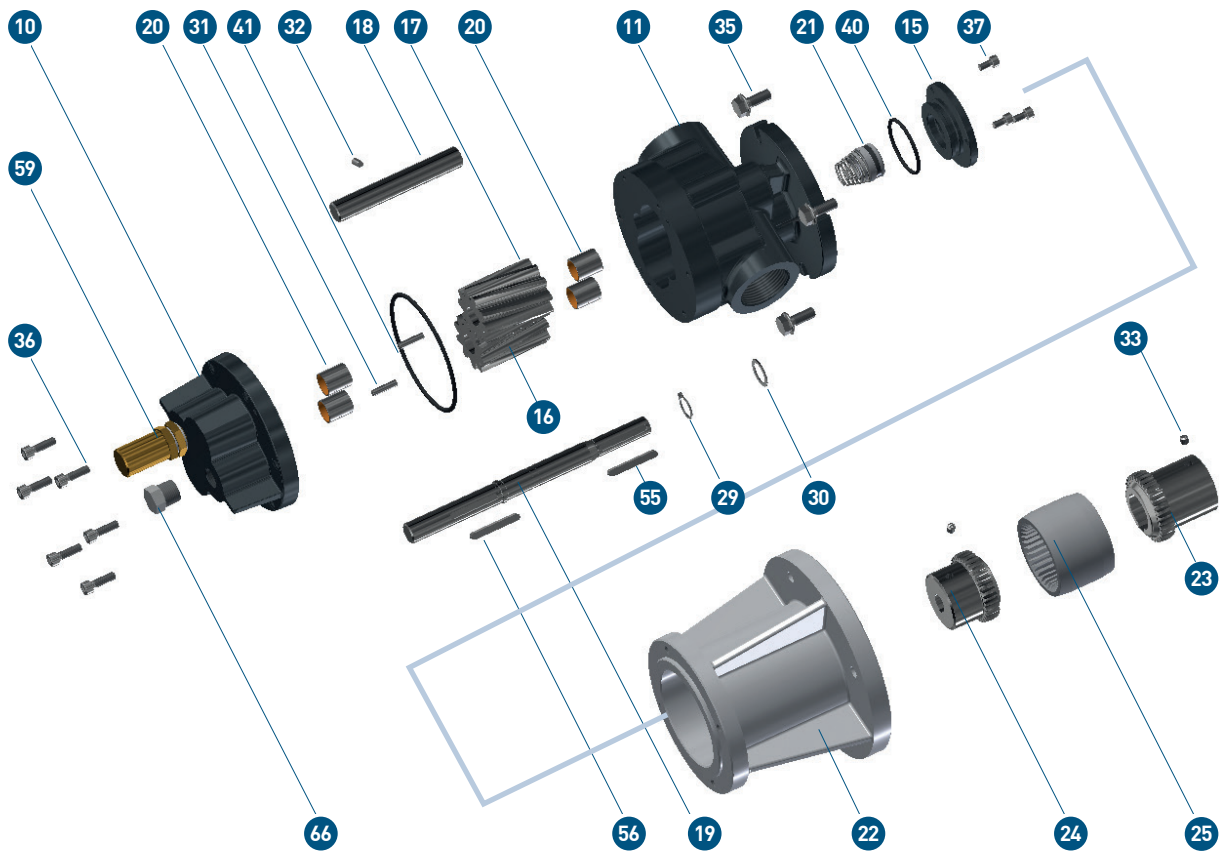

Fig. 412 – BFC pumps (mechanical seal version)



Tab. 411 - BMF, BCF, BFC part list

Ref.	Description	Ref.	Description	Ref.	Description	Ref.	Description
10	Pump rear cover	22	Bell housing	35	Screw	59	Relief valve kit
11	Pump housing	23	Half-coupling motor side	36	Screw	60	Valve cap
15	Mechanical seal housing	24	Half-coupling pump side	37	Screw	61	Valve locknut
16	Driving gear	25	Toothed sleeve	40	O-ring	62	Valve washer
17	Driven gear	29	Locking ring	41	O-ring	63	Valve poppet
18	Driven shaft	30	Ring seal	50	Lip seals	64	Valve adjusting screw
19	Driving shaft	31	Dowel pin	51	Lip seal housing	65	Valve spring
20	Sleeve bushings	32	Dowel pin	55	Feather key	66	Threaded cap
21	Mechanical seal	33	Grub screw	56	Feather key	80	Electric motor



5

B, BC, MBM, MBMC Series

Gear Pumps with Bare Shaft
and Feet Mounting,
Gear Pumps on Skid with Motor,
Heating Chamber Version,
ATEX version.

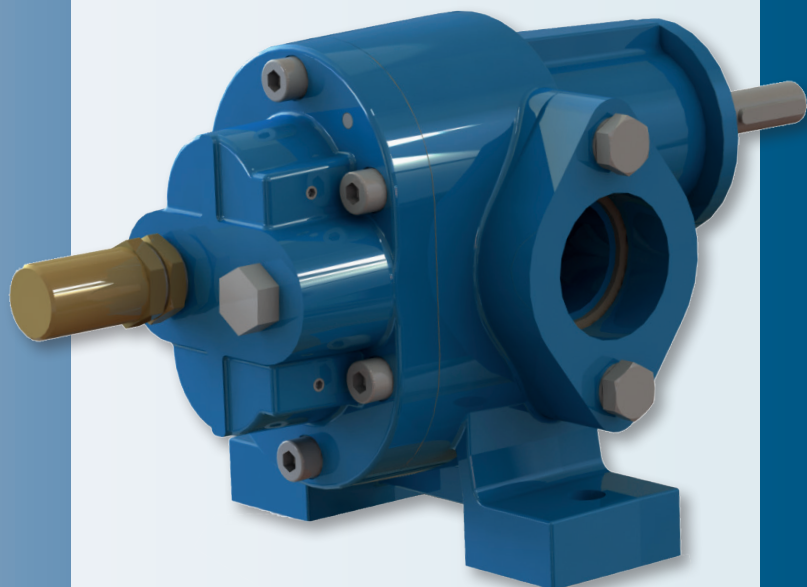

5.1 MAIN CHARACTERISTICS AND NOMINAL FLOW RATES

B, BC, MBM, MBMC pumps are volumetric gear pumps suitable for transferring lubricant viscous liquids without any suspended solids or abrasive substances. They are self-priming pumps used for a wide range of liquids with a viscosity from 1 to 20000 cSt. The speed of rotation is chosen according to the viscosity of the liquid. Flowrate range is from 5 to 800 L/min.

The standard construction consists of pump housing and cover in cast iron, shafts and gears in carbon steel, gaskets in Flexoid, sleeve bushings in Steel-Bronze-PTFE and a mechanical seal in ceramic-graphite-Viton. These pumps are supplied with a pressure relief valve in brass.

Nozzles in inlet and outlet are of the same diameter and positioned on the same axis.

A short and straight alignment of the flow channels provides for a good suction capability and a quiet running. The helical gears result in extremely low noise levels and reduced pressure pulsation.

B, BC pumps are typically installed on a skid and driven by an electric motor by means of an elastic coupling (MBM, MBMC series). The sizes from 10 to 400 are also available with a heating chamber integrated in the pump housing (BC, MBMC series).

Fig. 501 – B pump, standard version

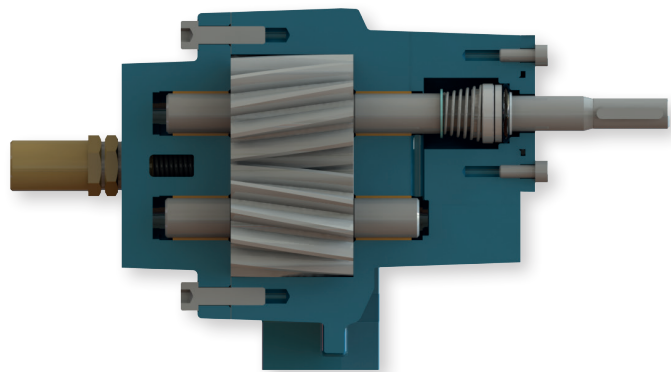

Table 501 shows the possible flow rates for non-pressurized pumping ($\Delta p=0$) and a 46 cSt fluid. The flow rate of gear pumps is virtually proportional to their

speed. The selected speeds are the most common speeds at rated power of industrial electric motors at 50 and 60Hz.

Tab. 501 – Nominal flow rates

PUMP SIZE (B, BC, MBM, MBMC)	Geometrical displacement V_{geo} [cm ³ /rev]	Nominal flow rate Q_{teq} [L/min] at Speed n [1/min]					
		690	830	950	1150	1450	1750
5	4.6	3.1	3.8	4.3	5.2	6.6	8.0
10	9.1	6.3	7.5	8.6	10.5	13.2	15.9
15	13.6	9.4	11.3	12.9	15.7	19.8	23.9
25	18.2	12.5	15.1	17.3	20.9	26.4	31.8
40	28.1	19.4	23.3	26.7	32.3	40.7	49.1
50	41.2	28.4	34.2	39.1	47.3	59.7	72.0
70	50.3	34.7	41.8	47.8	57.9	73.0	88.1
100	81.4	56.1	67.5	77.3	93.6	118.0	142.4
150	117.5	81.1	97.5	111.7	135.2	170.4	205.7
200	149.5	103.2	124.1	142.1	172.0	216.8	
250	185.4	127.9	153.9	176.1	213.2	268.8	
300	221.3	152.7	183.7	210.2	254.5	320.9	
350	257.2	177.5	213.5	244.3	295.8	372.9	
400	299.1	206.3	248.2	284.1	343.9	433.6	
500	369.6	255.0	306.8	351.1	425.1	535.9	
550	407.9	281.4	338.5	387.5	469.0	591.4	
600	446.1	307.8	370.3	423.8	513.0	646.8	
1200	885.5	611.0	734.9				
1600	1201.7	829.2	997.4				

5.2 MAIN OPTIONS

The main options available are:

- Counter-clockwise rotation (see paragraph 5.3)
- Options on relief valve (see paragraph 5.4)
- Special seals according to liquids and temperatures (see paragraph 5.5)
- On skid with electric motor (see paragraph 5.6)
- Constructions for corrosive liquids and aggressive environments (see paragraph 5.7)
- Heating solutions (see paragraph 5.8)
- Atex (see paragraph 5.9)
- Accessories (see paragraph 5.10)

5.3 SENSE OF ROTATION AND FLOW DIRECTION

The standard version of B and BC pumps can operate only in one direction of rotation: clockwise watching the pump shaft-end.

The direction of the fluid flow is shown by an arrow placed nearby the piping connections.

A proper mounting will keep the nameplate on the top side. The flow direction will be from the left side to the right side watching the pump shaft-end and the pressure side (delivery) will be at the right side.

On request a counterclockwise version can be supplied.

Fig. 502 – B, BC Series - Sense of rotation and flow direction

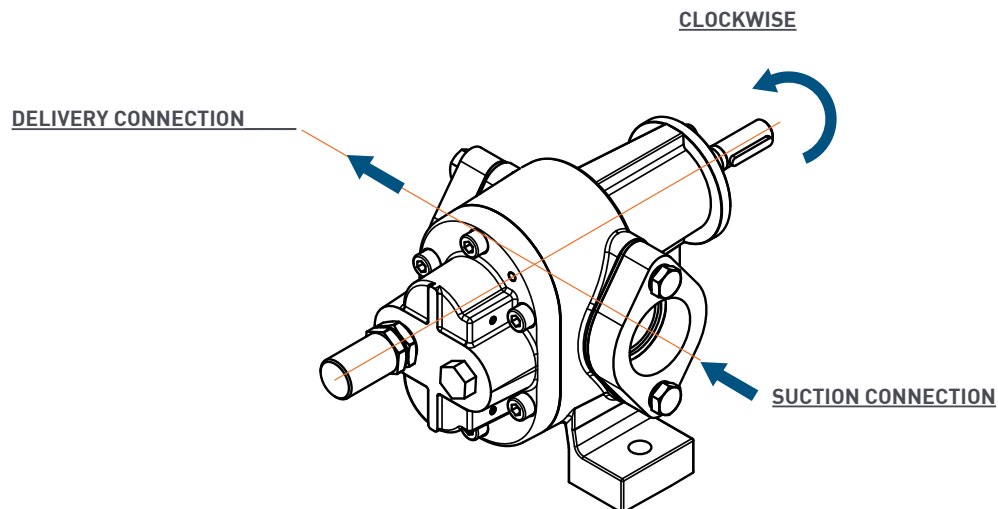

The standard version of MBM and MBMC pumps can operate only in one sense of rotation: clockwise watching the electric motor fan.

The sense of rotation of the motor, when properly connected to the mains, is shown by an arrow placed on

the fan cover. Watching the electric motor fan, the flow direction will be from the left side to the right side and the pressure side (delivery) will be at the right side.

On request a counterclockwise version can be supplied.

Fig. 503 – MBM, MBMC Series - Sense of rotation and flow direction

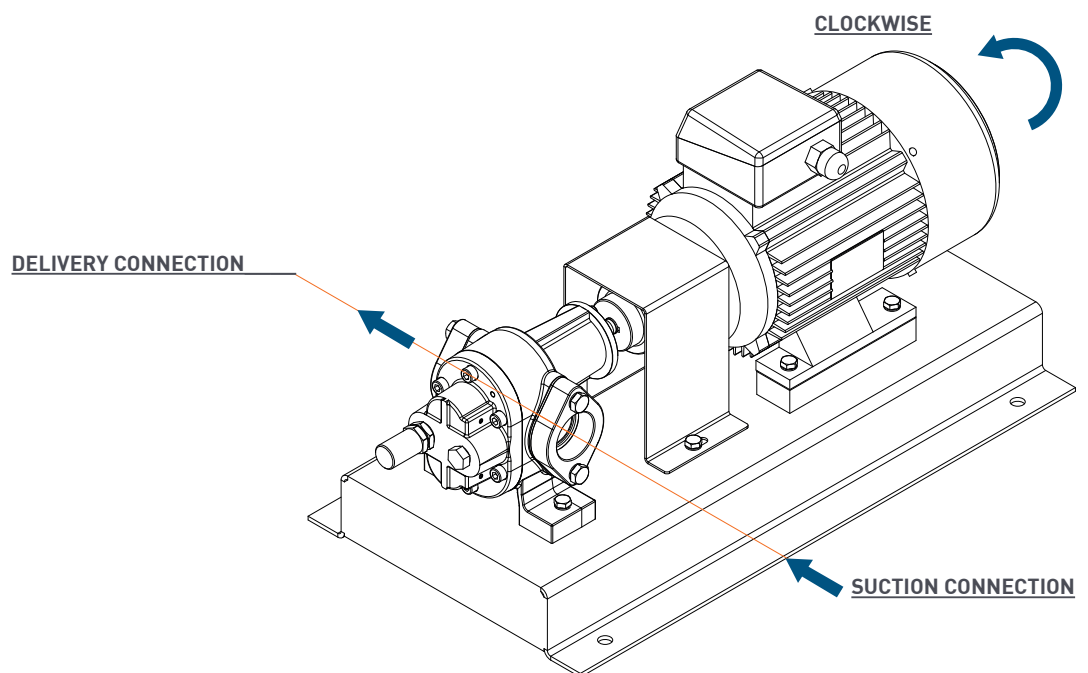

5.4 PRESSURE RELIEF VALVE

B, BC, MBM, MBMC pumps are supplied with a brass pressure relief valve as a standard. It works only on outlet, in one direction.

It may be used as a safety valve only for short-term operations. When a partial discharge flow has to be drained over a prolonged period of time, a separate by-pass valve with return to the suction tank has to be installed into the piping.

The pressure relief valve is designed as a spring-preloaded

piston valve. It is integrated into the pump's end cover. The spring pretension and the relative opening pressure can be adjusted by means of a screw. Different springs are also available to reach the desired adjustment range.

The pressure relief valve is available on request in stainless steel construction.

As an option the pumps can be supplied without relief valve.

5.5 SHAFT-END SEALS

The standard version is fitted with mechanical seal in ceramic-graphite-FPM. A number of different seals materials can be supplied for different liquids and operating temperatures.

On request:

- Radial lip-type seal in FPM (Viton), NBR or PTFE (Teflon)
- Packing seal in Acrylic yarn-PTFE
- Seal for high temperatures up to 200°C
- Reversible mechanical seal
- Double mechanical seal; available also with flushing system or quench

Fig. 504 - Mechanical seal

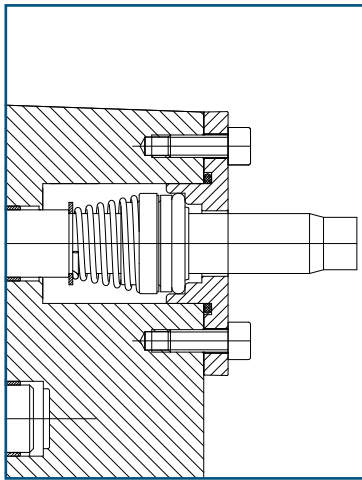

Fig. 505 - Lip seal

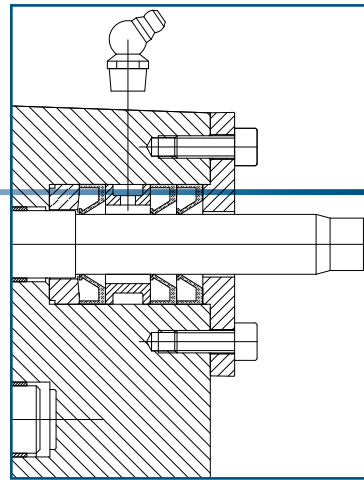
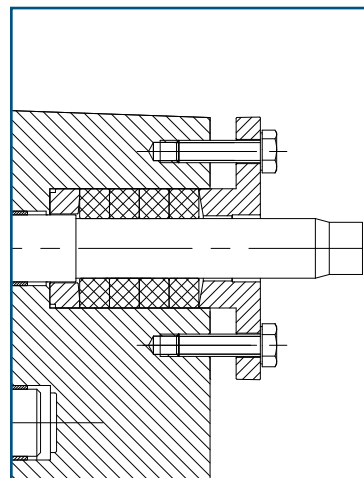

Fig. 506 - Packing seal



5.6 SKID VERSION WITH ELECTRIC MOTOR AND COUPLING (MBM, MBMC)

B, BC pumps can be mounted on a skid in galvanized steel and coupled to electric motors of different sizes through elastic coupling. Motors must be in frame B3.

MBMC (BC pump and motor on skid).

In table 502 the most common combinations of pumps and electric motors are listed.

The group is called MBM (B pump and motor on skid) and

Tab. 502 - Combinations of pumps and electric motors

PUMP SIZE (MBM, MBMC)	IEC Frame size									
	71	80	90	100	112	132	160	180	200	225
	Maximum rated power for a 4 poles motor at 400V/50Hz [kW]									
	0.37	0.75	1.50	3	4	7.5	15	22	22	30
5										
10										
15										
25										
40										
50										
70										
100										
150										
200										
250										
300										
350										
400										
500										
550										
600										
1200*										
1600*										

(*) 8 poles for pump models MBM1200 and MBM1600

The most common installed electric motors have the following characteristics:

- Standard motors in IP55, insulation class F available at 4, 6 and 8 poles
- Standard voltages for Three-phase motors $\leq 4\text{kW}$ 230/400V 50Hz - 265/460V 60Hz
- Standard voltages for Three-phase motors $\geq 5,5\text{kW}$ 400/690V 50Hz - 460/795V 60Hz
- Standard voltages for Single-phase motors 230V 50Hz

Special options on electric motors:

- Atex motors (see paragraph 5.9)
- Motors with built-in frequency converter
- Motors suitable for frequency converter connection
- Motor with forced ventilation

- Tropicalization
- Special voltages
- Protection IP56/IP65
- Protection IP67/IP68
- Thermistors PTC
- Special treatment for corrosive and saline environment
- Motors according to UL-CSA, NEMA, cURus and Marine regulations
- Insulation class H

Special motors available:

- Internal combustion engines
- Gearmotor
- Mechanical variator
- DC motors at 12V and 24V

5.7 VERSION FOR AGGRESSIVE LIQUIDS AND ENVIRONMENTS

B, BC, MBM, MBMC pumps can be supplied in a corrosion and acid-resistant construction.

Stainless-steel version

Pump housing, cover, shaft and gears in stainless steel and sleeve bushings in AISI 316-Bronze-PTFE.

Bronze version

Pump housing and cover in bronze, shaft and gears in stainless

steel and sleeve bushings in AISI 316-Bronze-PTFE.

Seals and gaskets materials are chosen according to the liquid pumped.

Many combinations suitable for corrosive liquids and aggressive environment can be supplied as follows:

- Gears in bronze
- Sleeve bushings in PTFE or Tecapeek

5.8 VERSION WITH HEATING CHAMBER (BC, MBMC)

BC pumps, available from size 10 to 400, have got a heating chamber integrated in the pump housing.

BC pumps are useful when the pumped liquid (such as bitumen or wax) needs to be heated in order to prevent the liquid from hardening. The heating chamber works with a circulation of diathermic oil, hot water or saturated vapor.

A different heating solution, as an alternative to the heating chamber, is to provide holes for glow-plug or electric resistances (not included).

MBMC serie consists in a BC pump mounted on a skid and coupled to electric motor by means elastic coupling.

5.9 VERSION FOR HAZARDOUS AREAS (ATEX)

5.9.1 The Atex Directives

ATEX is an abbreviation for "ATmosphere EXplosible" and refers to the following two European Union Directives:

- the Directive 2014/34/EU, for equipment and protective systems intended for use in potentially explosive atmospheres, is mandatory for manufacturers and states the classification criteria (ATEX CATEGORIES) and the manufacturing, marking and certification rules for such products;
- the Directive 99/92/EC, for the minimum requirements for improving the safety and health protection

of workers potentially at risk from explosive atmospheres, is mandatory for employers and states the classification criteria (ATEX ZONES) for working places where could happen a potentially explosive atmosphere. This Directive set also the connection between ATEX ZONES and ATEX CATEGORIES.

The Directive 2014/34/EU has replaced the former ATEX 94/9/EC and states that the electric products and the mechanical products, pumps included, intended to be used in hazardous areas, must be designed and manufactured in order to avoid being themselves a source of ignition.

Tab. 503 – Atex Categories according to Directive 2014/34/EU

Protection level (Guaranteed by the equipment Category)	Mine	Surface	
		Gas	Combustible dust
Very High	M1	1G	1D
High	M2	2G	2D
Normal	not provided for	3G	3D

Tab. 504 - Atex Zones according to Directive 99/92/EC

Hazardous level of the perational Zone Explosive atmosphere	Usage area in the presence of	
	Gas	Combustible dust
Always present	Zone 0	Zone 20
Probable	Zone 1	Zone 21
Unlikely	Zone 2	Zone 22

Tab. 505 - Association Zone and Category according to Atex 99/92/EC – gas

Explosive atmosphere	Danger zone	Protection guaranteed by equipment	Equipment category
Always present	0	Very High	1G
Probable	1	High	2G
Unlikely	2	Normal	3G

Tab. 506 - Association Zone and Category according to Atex 99/92/EC – dust

Explosive atmosphere	Danger zone	Protection guaranteed by equipment	Equipment category
Always present	20	Very High	1D
Probable	21	High	2D
Unlikely (conductive dusts)	22	Normal	2D
Unlikely (non conductive dusts)	22	Normal	3D

5.9.2 The Atex pumps features

The Atex version of pumps B, BC on skid with Atex electric motor coupled with elastic coupling, (Atex electric pumps MBM, MBMC), is available for surface applications Group II (not for mines, Group I).

They belong to the Atex categories

- 2G, 3G for gases and vapours up to Group IIC (hydrogen, acetylene...)
- 2D, 3D for dusts up to Group IIIC (combustible metallic dust)

5.9.3 The Atex pumps conformity and marking

The Atex MBM, MBMC electric pumps comply with the Directive 2014/34/EU and the relevant technical assessment documentation has been filed at INERIS (Notified Body NB0080).

They are marked in conformity with the Directive 2014/34/EU and with ISO EN 80079-36 / 80079-37 standards as follows:

- II 2G Ex h IIC Tx Gb for usage in the presence of gases in Zone 1 and Zone 2
- II 2D Ex h IIIC Txxx°C Db for usage in the presence of dusts in Zone 21 and Zone 22.

The electric motor driving the pump, manufactured in compliance with IEC EN 60079-0, 60079-1, 60079-7 (for gases and vapours) or in compliance with IEC EN 60079-0, 60079-31 (for combustible dusts) matches the pump's protection mode and the customer's requirements.

The temperature class Tx (gases) or the maximum

The Atex MBM, MBMC electric pumps are available

- in all constructions (cast iron, bronze, stainless steel)
- with all shaft-end seals (mechanical, lip ring, packing)
- for ambient temperature between -20°C and 40°C
- for fluid viscosity up to 20.000 cSt
- for maximum fluid temperature of 180°C
- for maximum fluid conductivity of 1000 pS/m

surface temperature Txxx°C (dusts) are mainly linked to the maximum temperature of the pumped fluid. Therefore, the end user is responsible to limit the fluid temperature in order to keep Tx or Txxx°C below the maximum values defined by the Zone classification.

In addition to these electric pumps the Atex bare shaft pumps B, BC are available. They comply with the Directive 2014/34/EU and the relevant technical assessment documentation has been filed at INERIS (Notified Body NB0080).

They are marked in conformity with the Directive 2014/34/EU and with ISO EN 80079-36 / 80079-37 standards as follows:

- II 2G Ex h IIC Tx Gb for usage in the presence of gases in Zone 1 and Zone 2
- II 2D Ex h IIIC Txxx°C Db for usage in the presence of dusts in Zone 21 and Zone 22.

5.10 ACCESSORIES

- Pump on trolley
- Special tank for liquid container
- Control panel
- ON/OFF switches
- Reversing switches
- Piping
- Heated piping
- Valves
- Pressure gauge and pressure switch
- External cooling system
- Electric cables

5.11 SOUND LEVEL

The sound level has been measured in dB(A) at 1m distance, at 1450 1/min with gear oil (viscosity 46 cSt).

Tab. 507 – Sound level

PUMP SIZE (B, BC, MBM, MBMC)	Sound level dB(A) at pressure			
	2 bar	5 bar	10 bar	12 bar
5	66.0	66.0	68.0	68.0
10	66.0	66.0	68.0	68.0
15	66.0	66.0	68.0	68.0
25	66.0	66.0	68.0	68.0
40	75.4	77.0	77.5	77.5
50	75.4	77.0	77.5	77.5
70	75.4	77.0	77.5	77.5
100	77.0	78.0	79.0	83.0
150	77.0	78.0	79.0	83.0
200	82.0	82.5	85.0	86.0
250	82.0	82.5	85.0	86.0
300	82.0	82.5	85.0	86.0
350	83.0	83.0	86.0	86.0
400	83.0	83.0	86.0	86.0
500	86.0	87.0	89.0	90.0
550	86.0	87.0	89.0	90.0
600	86.0	87.0	89.0	90.0
1200	84.5	85.5	86.0	86.5
1600	84.5	85.5	86.0	86.5

5.12 PUMP SELECTION AND PERFORMANCE DATA

In table 508 are listed the actual delivery Q_{eff} and required power P_{mec} for each pump size at different speeds and pressures.

The data refer to a mineral oil ISO46 (Kinematic viscosity 46 cSt at 40°C).

The rated power for the the drive motor should be 20% higher than the required power P_{mec} .

For different viscosities please ask the performances (delivery and power) to our Technical department.

As a general rule the flow rate is approximately proportional to the speed.

A lower viscosity may lead to a loss of the net delivery and a higher viscosity may lead to an increase of the net delivery.

When dimensioning please consider the maximum viscosity, usually at the start-up phase.

Pump selection, delivery and required power at different speeds:

- 1) Given the project delivery Q_{pro} [L/min] and speed n_{pro} [1/min] calculate the project displacement V_{pro} [cm³/rev]:

$$V_{\text{pro}} = 1000 \times Q_{\text{pro}} / n_{\text{pro}}$$

- 2) Select the Pump Type with the geometrical displacement V_{geo} closer to V_{pro} .

- 3) Read from the Performance Table the delivery at 1450 1/min and at the given pressure p:

$$Q_{1450, p} \text{ [L/min]}$$

- 4) Calculate the actual delivery Q [L/min] at n_{pro} and p:

$$Q = Q_{1450, p} + V_{\text{geo}} \times (n_{\text{pro}} - 1450) / 1000$$

- 5) Read from the Performance Table the required power and actual delivery of the selected Pump Type at the closer speed n_x to n_{pro} and at p:

$$P_{n_x, p} \text{ [kW]}, Q_{n_x, p} \text{ [L/min]}$$

- 6) Calculate the actual required power P at n_{pro} and p [kW]:

$$P = P_{n_x, p} \times Q / Q_{n_x, p}$$

Tab. 508 - Performance data at 690, 830, 950, 1150, 1450, 1750 1/min and 46 cSt

PUMP SIZE (B, BC, MBM, MBMC)	Geometrical displacement V_{geo} [cm ³ /rev]	Pressure p [bar]	Speed n [1/min]											
			690		830		950		1150		1450		1750	
			Q_{eff} [L/min]	P_{mec} [kW]	Q_{eff} [L/min]	P_{mec} [kW]	Q_{eff} [L/min]	P_{mec} [kW]	Q_{eff} [L/min]	P_{mec} [kW]	Q_{eff} [L/min]	P_{mec} [kW]	Q_{eff} [L/min]	P_{mec} [kW]
5	4.6	2	3.0	0.04	3.6	0.05	4.2	0.06	5.0	0.08	6.4	0.10	7.7	0.13
		5	2.8	0.10	3.4	0.12	3.9	0.14	4.8	0.17	6.1	0.21	7.4	0.2
		10	2.5	0.19	3.0	0.22	3.5	0.26	4.3	0.31	5.6	0.38	6.8	0.5
		12	2.3	0.22	2.9	0.27	3.3	0.31	4.1	0.37	5.3	0.45	6.6	0.5
10	9.1	2	6.0	0.05	7.3	0.06	8.3	0.08	10.1	0.10	12.8	0.13	15.5	0.2
		5	5.6	0.13	6.9	0.15	7.9	0.18	9.6	0.2	12.3	0.3	14.9	0.3
		10	5.0	0.25	6.2	0.30	7.1	0.34	8.8	0.4	11.3	0.5	13.9	0.6
		12	4.8	0.30	5.9	0.36	6.8	0.41	8.5	0.5	11.0	0.6	13.5	0.7
15	13.6	2	9.0	0.08	10.8	0.10	12.4	0.12	15.1	0.2	19.1	0.2	23.1	0.3
		5	8.3	0.19	10.1	0.23	11.6	0.27	14.2	0.3	18.1	0.4	22.0	0.5
		10	7.1	0.37	8.8	0.45	10.2	0.52	12.7	0.6	16.4	0.8	20.2	1.0
		12	6.7	0.44	8.3	0.54	9.7	0.62	12.1	0.7	15.7	0.9	19.5	1.1
25	18.2	2	12.0	0.08	14.4	0.11	16.6	0.13	20.1	0.2	25.5	0.2	30.9	0.3
		5	11.1	0.2	13.4	0.2	15.5	0.3	19.0	0.4	24.2	0.5	29.5	0.6
		10	9.6	0.4	11.8	0.5	13.7	0.6	17.0	0.7	22.0	0.9	27.2	1.0
		12	9.0	0.5	11.1	0.6	13.0	0.7	16.2	0.8	21.2	1.0	26.2	1.2
40	28.1	2	18.4	0.2	22.2	0.2	25.5	0.2	31.0	0.3	39.3	0.4	47.6	0.5
		5	17.0	0.4	20.6	0.5	23.8	0.5	29.1	0.7	37.1	0.9	45.2	1.1
		10	14.6	0.8	18.0	0.9	20.9	1.1	25.9	1.3	33.5	1.7	41.3	2.0
		12	13.6	0.9	16.9	1.1	19.7	1.3	24.6	1.6	32.1	2.0	39.8	2.4
50	41.2	2	27.7	0.3	33.4	0.4	38.4	0.4	46.5	0.6	58.7	0.8	70.9	1.1
		5	26.7	0.5	32.5	0.6	37.5	0.7	45.5	0.9	57.5	1.3	69.5	1.7
		10	25.1	0.8	30.9	0.9	36.0	1.1	43.8	1.5	55.5	2.1	67.3	2.7
		12	24.5	0.9	30.3	1.1	35.4	1.2	43.1	1.8	54.7	2.4	66.4	3.0
70	50.3	2	33.6	0.3	40.8	0.4	46.8	0.5	56.7	0.7	71.5	0.9	86.4	1.2
		5	31.9	0.5	39.4	0.8	45.2	0.9	54.9	1.2	69.4	1.6	83.9	2.0
		10	29.2	0.9	37.2	1.3	42.7	1.6	51.9	2.0	65.8	2.7	79.8	3.4
		12	28.1	1.0	36.2	1.6	41.6	1.9	50.7	2.4	64.4	3.2	78.2	4.0
100	81.4	2	55.2	0.4	66.7	0.5	76.5	0.5	92.9	0.7	117.0	1.0	141.3	1.2
		5	53.8	0.7	65.3	0.9	75.2	1.0	91.9	1.2	115.6	1.7	139.7	2.2
		10	51.5	1.3	63.1	1.5	73.2	1.8	90.2	2.1	113.3	3.0	136.9	3.8
		12	50.6	1.5	62.2	1.8	72.4	2.1	89.5	2.5	112.3	3.5	135.8	4.4
150	117.5	2	79.2	0.6	95.7	0.7	110.0	0.9	133.3	1.1	168.1	1.6	203.0	2.0
		5	76.4	1.0	92.9	1.3	107.6	1.6	130.4	2.1	164.7	2.8	198.9	3.5
		10	71.7	1.8	88.3	2.2	103.6	2.9	125.7	3.6	158.9	4.8	192.2	6.1
		12	69.9	2.1	86.5	2.6	102.0	3.4	123.8	4.2	156.6	5.6	189.5	7.1
200	149.5	2	100.1	0.7	123.3	0.9	139.0	1.1	169.1	1.5	213.4	2.1		
		5	95.4	1.3	123.8	1.6	134.4	1.9	164.8	2.5	208.3	3.4		
		10	87.7	2.3	124.0	2.8	126.8	3.2	157.7	4.2	199.9	5.6		
		12	84.6	2.7	124.0	3.3	123.8	3.8	154.8	4.8	196.5	6.5		

Different viscosities, working pressure, rotational speed and ambient conditions can change performance data shown in the table.

Tab. 508 - Performance data at 690, 830, 950, 1150, 1450, 1750 1/min and 46 cSt

PUMP SIZE (B, BC, MBM, MBMC)	Geometrical displacement V_{geo} [cm ³ /rev]	Pressure p [bar]	Speed n [1/min]											
			690		830		950		1150		1450		1750	
			Q_{eff} [L/min]	P_{mec} [kW]	Q_{eff} [L/min]	P_{mec} [kW]	Q_{eff} [L/min]	P_{mec} [kW]	Q_{eff} [L/min]	P_{mec} [kW]	Q_{eff} [L/min]	P_{mec} [kW]	Q_{eff} [L/min]	P_{mec} [kW]
250	185.4	2	124.5	0.9	150.5	1.2	173.1	1.5	209.8	1.9	264.7	2.7		
		5	119.3	1.7	145.5	2.1	168.6	2.5	204.6	3.2	258.6	4.4		
		10	110.7	3.0	137.1	3.7	161.1	4.2	195.9	5.4	248.3	7.3		
		12	107.3	3.6	133.7	4.3	158.1	4.9	192.4	6.2	244.2	8.4		
300	221.3	2	146.6	1.1	177.2	1.4	203.6	1.7	247.7	2.2	314.6	3.1		
		5	137.5	2.0	167.5	2.5	193.6	3.0	237.4	3.7	305.2	5.1		
		10	122.3	3.6	151.4	4.4	176.9	5.1	220.3	6.3	289.5	8.5		
		12	116.2	4.2	144.9	5.2	170.2	6.0	213.4	7.3	283.3	9.8		
350	257.2	2	169.6	1.1	204.9	1.4	238.1	1.7	288.5	2.2	364.3	2.9		
		5	157.7	2.2	192.1	2.6	228.7	3.1	277.7	3.9	351.3	5.3		
		10	137.9	4.1	170.8	4.7	213.1	5.5	259.5	6.9	329.7	9.2		
		12	130.0	4.8	162.2	5.5	206.8	6.4	252.3	8.1	321.0	10.8		
400	299.1	2	198.5	1.3	239.8	1.6	275.2	1.9	335.2	2.5	423.2	3.4		
		5	186.9	2.6	227.1	3.2	261.9	3.6	322.1	4.5	407.5	6.1		
		10	167.4	4.9	206.0	5.7	239.8	6.3	300.2	7.9	381.4	10.6		
		12	159.6	5.8	197.6	6.7	230.9	7.4	291.5	9.3	371.0	12.4		
500	369.6	2	248.7	1.8	302.4	2.3	346.3	2.7	419.4	3.5	529.1	4.8		
		5	238.8	3.3	295.5	4.3	338.5	5.1	410.3	6.5	518.2	8.7		
		10	222.4	5.8	284.0	7.6	325.6	9.0	395.2	11.3	500.0	15.1		
		12	215.8	6.8	279.4	9.0	320.5	10.5	389.2	13.3	492.7	17.7		
550	407.9	2	271.1	1.9	328.6	1.4	380.1	2.9	460.3	3.7	580.8	5.0		
		5	255.6	3.6	313.8	1.2	368.9	5.4	447.2	6.8	564.9	9.2		
		10	229.8	6.5	289.1	1.1	350.4	9.6	425.5	12.1	538.4	16.0		
		12	219.4	7.7	279.2	1.1	343.0	11.3	416.7	14.2	527.8	18.8		
600	446.1	2	299.8	1.8	361.1	2.3	413.8	2.7	501.6	3.4	633.5	4.7		
		5	287.9	4.0	347.6	4.9	398.9	5.6	484.6	7.0	613.7	9.0		
		10	268.1	7.6	325.0	9.2	374.0	10.5	456.3	12.8	580.8	16.2		
		12	260.2	9.1	315.9	10.9	364.1	12.5	445.0	15.2	567.6	19.1		
1200	885.5	2	595.4	6.3	720.2	8.2								
		5	572.2	11.5	698.1	14.1								
		10	533.4	20.0	661.2	24.0								
		12	517.9	23.4	646.5	28.0								
1600	1201.7	2	809.0	7.5	975.8	9.7								
		5	778.9	14.9	943.4	18.4								
		10	728.6	27.2	889.3	32.9								
		12	708.5	32.1	867.7	38.7								

Different viscosities, working pressure, rotational speed and ambient conditions can change performance data shown in the table.

5.13 OVERALL DIMENSIONS AND WEIGHTS

5.13.1 B

Fig. 507 - B5 to B40 dimensional drawing

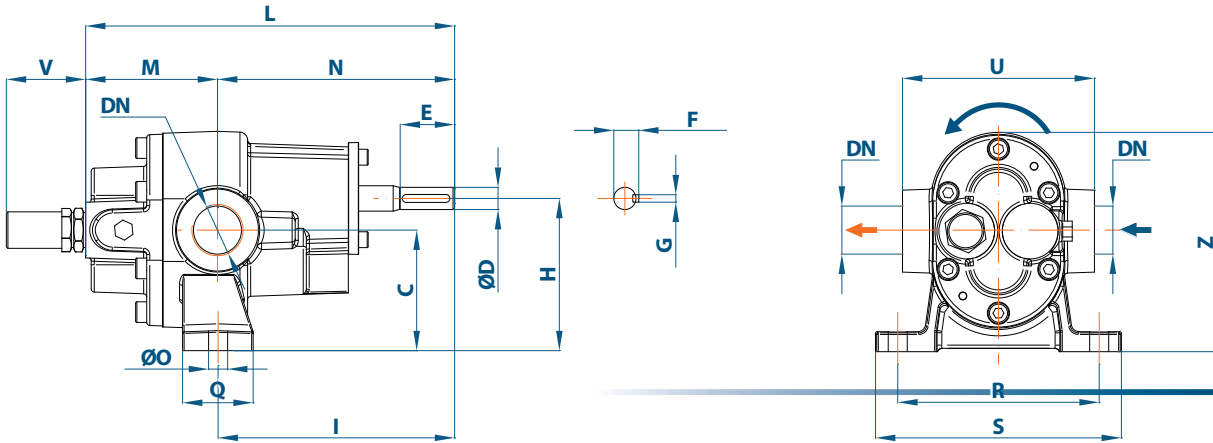

Tab. 509 - B5 to B40 overall dimensions and weights

PUMP SIZE (B)	DN ISO 228-1	C	D	E	F	G	H	I	L	M	N	O	Q	R	S	U	V	Z	Weight [kg]
5	G 1/2"	64	12	28	13.5	4	80	98.5	162	64	98	10.5	36	105	130	90	50	117	3.4
10	G 1/2"	64	12	28	13.5	4	80	98.5	172	74	98	10.5	36	105	130	90	50	117	3.8
15	G 3/4"	64	12	28	13.5	4	80	114.5	182.5	68	114.5	10.5	41.5	105	130	95	50	117	4.1
25	G 3/4"	64	12	30	13.5	4	80	114.5	192.5	78	114.5	10.5	41.5	105	130	95	50	117	4.5
40	G 1"	76	14	35	16	5	96	149.5	232.5	83	149.5	10.5	44.5	127	155	121	50	139	7.2

Dimensions in mm; tolerances allowed.

Fig. 508 - B50 to B70 dimensional drawing

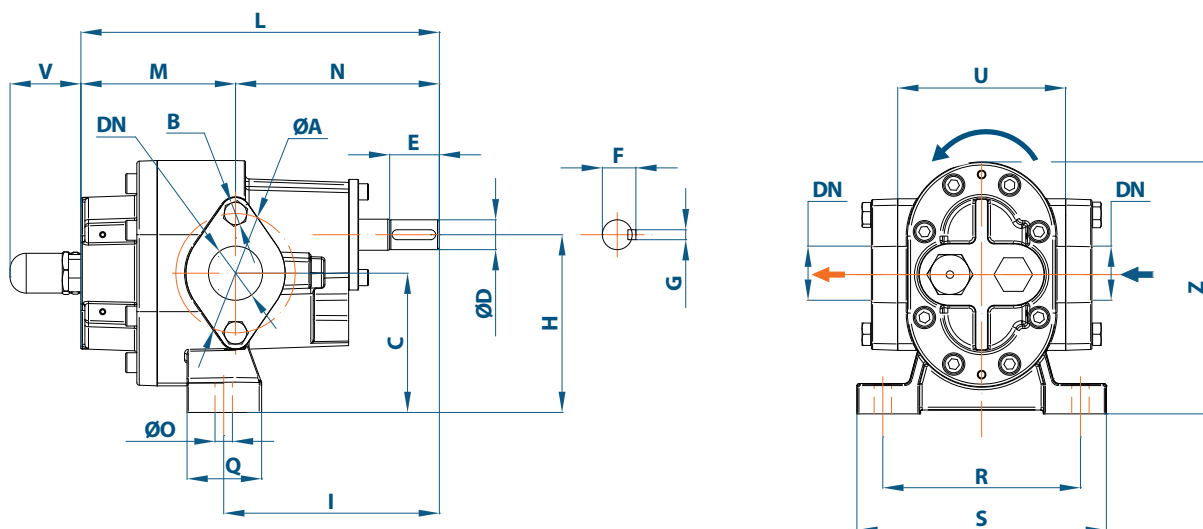

Tab. 510 - B50 to B70 overall dimensions and weights

PUMP SIZE (B)	DN ISO 228-1	A	B	C	D	E	F	G	H	I	L	M	N	O	Q	R	S	U	V	Z	Weight [kg]
		50	G1"1/2	75	N°2-M10	91.5	14	35	16	5	114	156	236	87	149	12	53	127	157	98	
70	G1"1/2	75	N°2-M10	91.5	14	35	16	5	114	156	246	90	156	12	53	127	157	98	50	162	10.7

Dimensions in mm; tolerances allowed.

Fig. 509 - B100 to B150 dimensional drawing

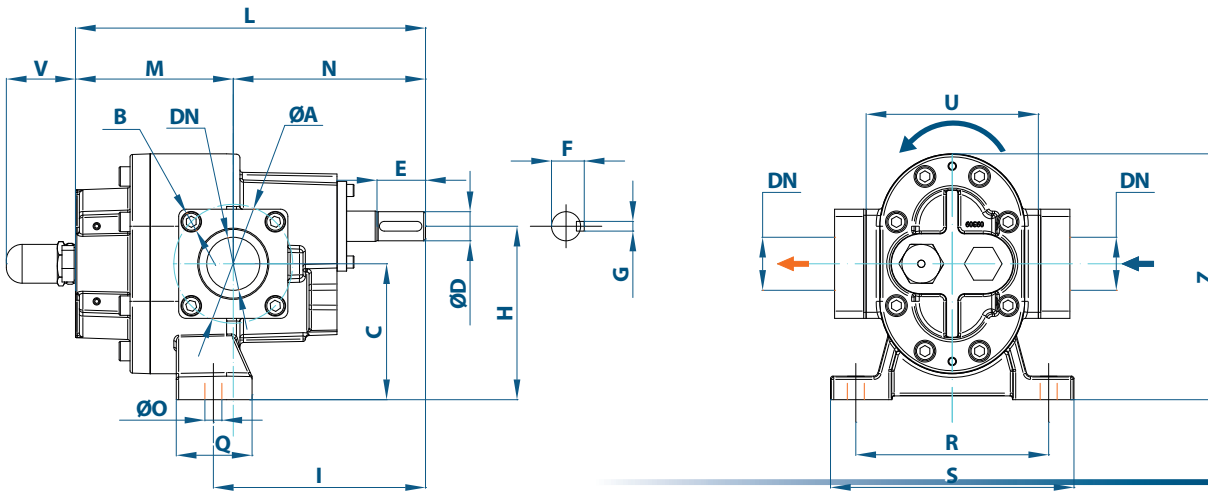

Tab. 511 - B100 to B150 overall dimensions and weights

PUMP SIZE (B)	DN	A	B	C	D	E	F	G	H	I	L	M	N	O	Q	R	S	U	V	Z	Weight [kg]
	ISO 228-1																				
100	G 2"	98	N*4-M10	111	24	40	27	8	142	175	268.5	110	158.5	14	62.5	159	201	142	57	203	21.5
150	G 2"	98	N*4-M10	111	24	40	27	8	142	175	288.5	130	158.5	14	62.5	159	201	142	57	203	24

Dimensions in mm; tolerances allowed.

Fig. 510 - B200 to B600 dimensional drawing

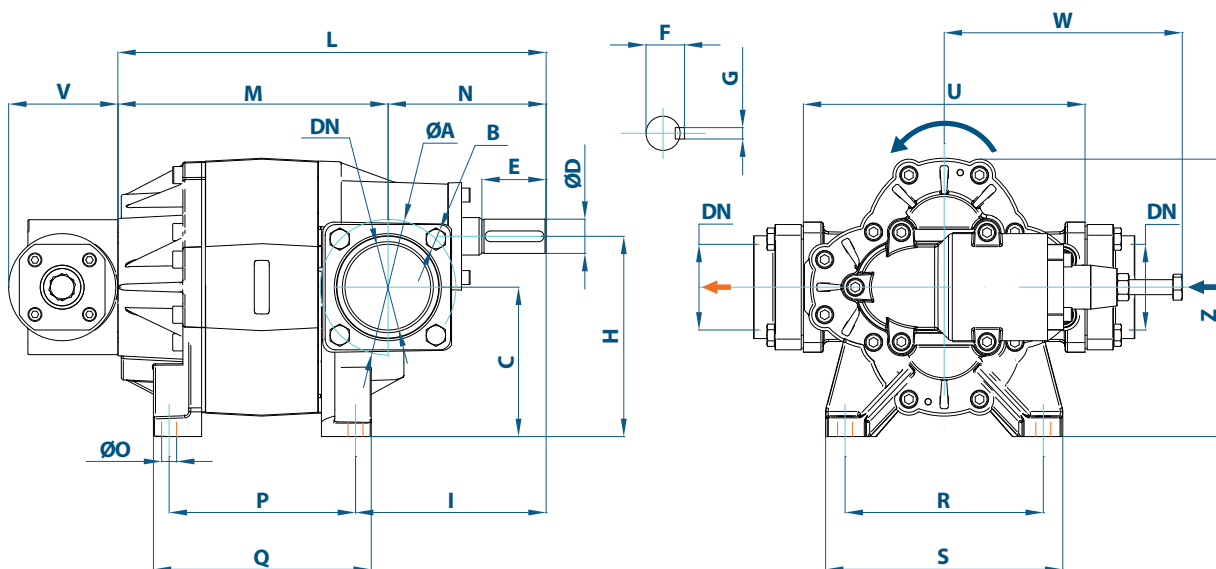

Tab. 512 - B200 to B600 overall dimensions and weights

PUMP SIZE (B)	DN ISO 228-1	Dimensions																				Weight [kg]	
		A	B	C	D	E	F	G	H	I	L	M	N	O	P	Q	R	S	U	V	W		Z
200	G 2"1/2	115	N*4-M12	106	28	60	31	8	142	168	323	178	145	13	118	151	139	171	210	71	210	200	31.4
250	G 2"1/2	115	N*4-M12	106	28	60	31	8	142	168	335	190	145	13	130	163	139	171	210	71	210	200	33
300	G 2"1/2	115	N*4-M12	106	28	60	31	8	142	168	347	202	145	13	142	175	139	171	210	71	210	200	35
350	G 2"1/2	115	N*4-M12	106	28	60	31	8	142	168	359	214	145	13	154	187	139	171	210	71	210	200	36
400	G 2"1/2	115	N*4-M12	106	28	60	31	8	142	168	373	228	145	13	168	201	139	171	210	71	210	200	38
500	G 3"	127	N*4-M12	139.5	32	60	35	10	187	181	382	234	148	13	151	169	185	222	263	102	222	260	60
550	G 3"	127	N*4-M12	139.5	32	60	35	10	187	181	391	243	148	13	160	178	185	222	263	102	222	260	61
600	G 3"	127	N*4-M12	139.5	32	60	35	10	187	181	400	252	148	13	169	187	185	222	263	102	222	260	63

Dimensions in mm; tolerances allowed.

Fig. 511 - B1200 to B1600 dimensional drawing

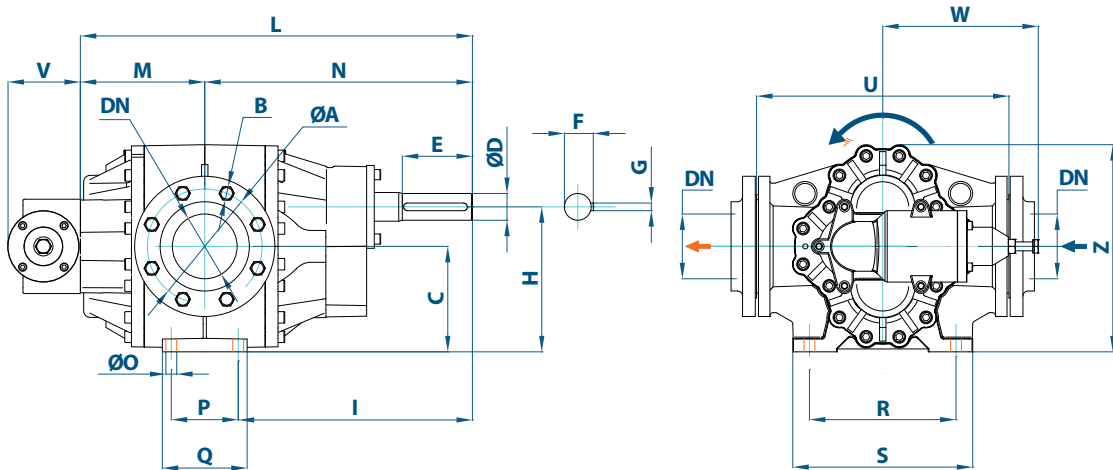

Tab. 513 - B1200 to B1600 overall dimensions and weights

PUMP SIZE (B)	DN UNI 2254																				Weight [kg]		
		A	B	C	D	E	F	G	H	I	L	M	N	O	P	Q	R	S	U	V		W	Z
1200	G 4"	180	N°8-M16	165.5	42	110	45	12	227.5	342.5	565	170	395	17	105	133	230	282	396	113.5	244	325	133
1600	G 4"	180	N°8-M16	165.5	42	110	45	12	227.5	367.5	615	195	420	17	105	133	230	282	396	113.5	244	325	158

Dimensions in mm; tolerances allowed.

5.13.2 BC

Fig. 512 - BC10 to BC25 dimensional drawing

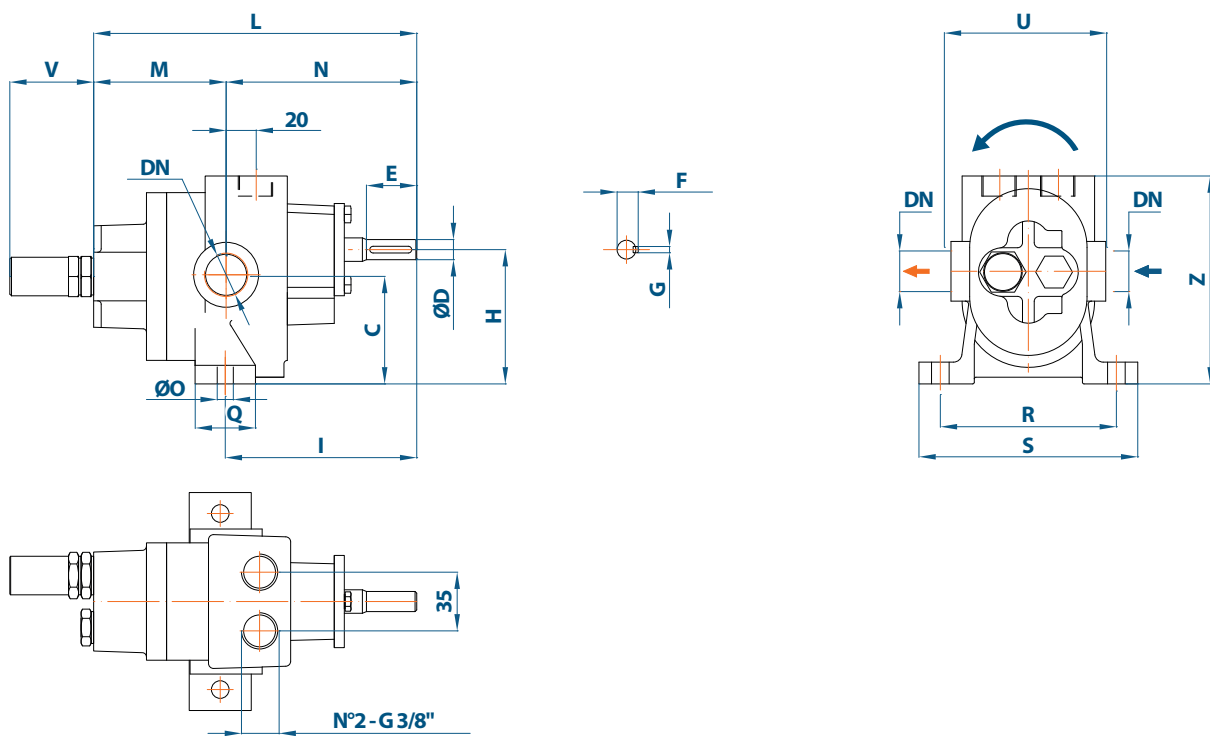

Tab. 514 - BC10 to BC25 overall dimensions and weights

PUMP SIZE (BC)	DN ISO 228-1	C	D	E	F	G	H	I	L	M	N	O	Q	R	S	U	V	Z	Weight [kg]
10	G 1/2"	64	12	28	13.5	4	80	98.5	172	74	98	10.5	36	105	130	90	50	117	3.8
15	G 3/4"	64	12	28	13.5	4	80	114.5	182.5	68	114.5	10.5	41.5	105	130	95	50	117	4.1
25	G 3/4"	64	12	30	13.5	4	80	114.5	192.5	78	114.5	10.5	41.5	105	130	95	50	117	4.5

Dimensions in mm; tolerances allowed.

Fig. 513 - BC50 to BC70 dimensional drawing

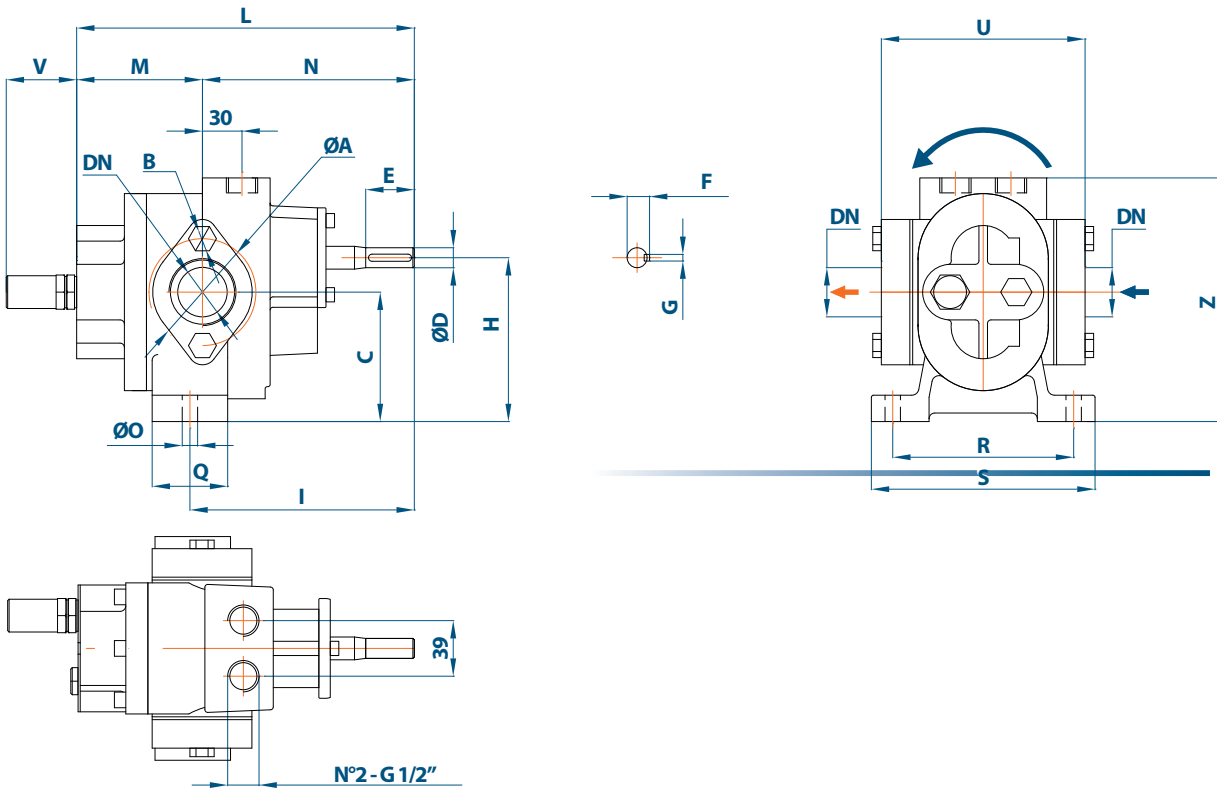

Tab. 515 - BC50 to BC70 overall dimensions and weights

PUMP SIZE (BC)	DN ISO 228-1	A	B	C	D	E	F	G	H	I	L	M	N	O	Q	R	S	U	V	Z	Weight [kg]
50	G 1"1/2	75	N°2-M10	91.5	14	35	16	5	114	156	236	87	149	12	53	127	157	98	50	162	9.8
70	G 1"1/2	75	N°2-M10	91.5	14	35	16	5	114	156	246	90	156	12	53	127	157	98	50	162	10.7

Dimensions in mm; tolerances allowed.

Fig. 514 - BC100 to BC150 dimensional drawing

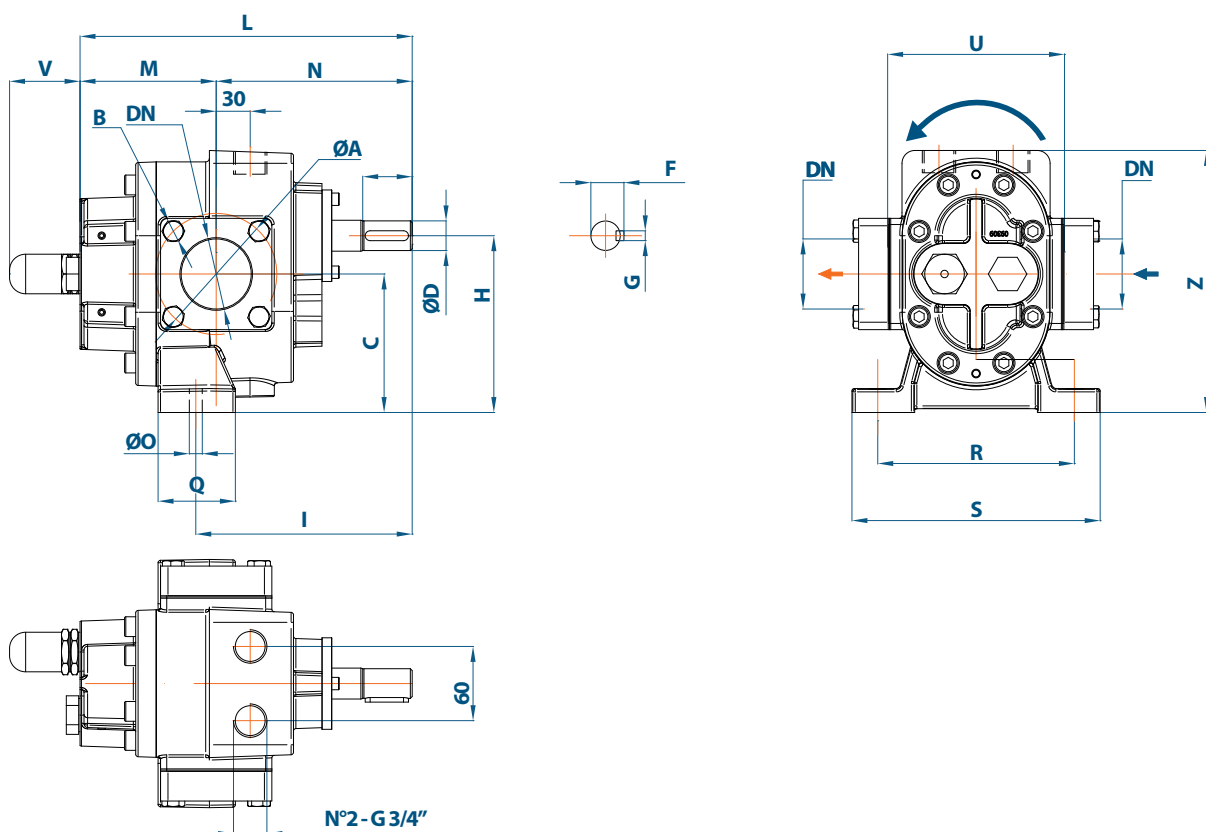

Tab. 516 - BC100 to BC150 overall dimensions and weights

PUMP SIZE (BC)	DN ISO 228-1	A	B	C	D	E	F	G	H	I	L	M	N	O	Q	R	S	U	V	Z	Weight [kg]
		100	G 2"	98	N°4-M10	111	24	40	27	8	142	175	268.5	110	158.5	14	62.5	159	201	142	
150	G 2"	98	N°4-M10	111	24	40	27	8	142	175	288.5	130	158.5	14	62.5	159	201	142	57	203	24

Dimensions in mm; tolerances allowed.

Fig. 515 - BC200 to BC400 dimensional drawing

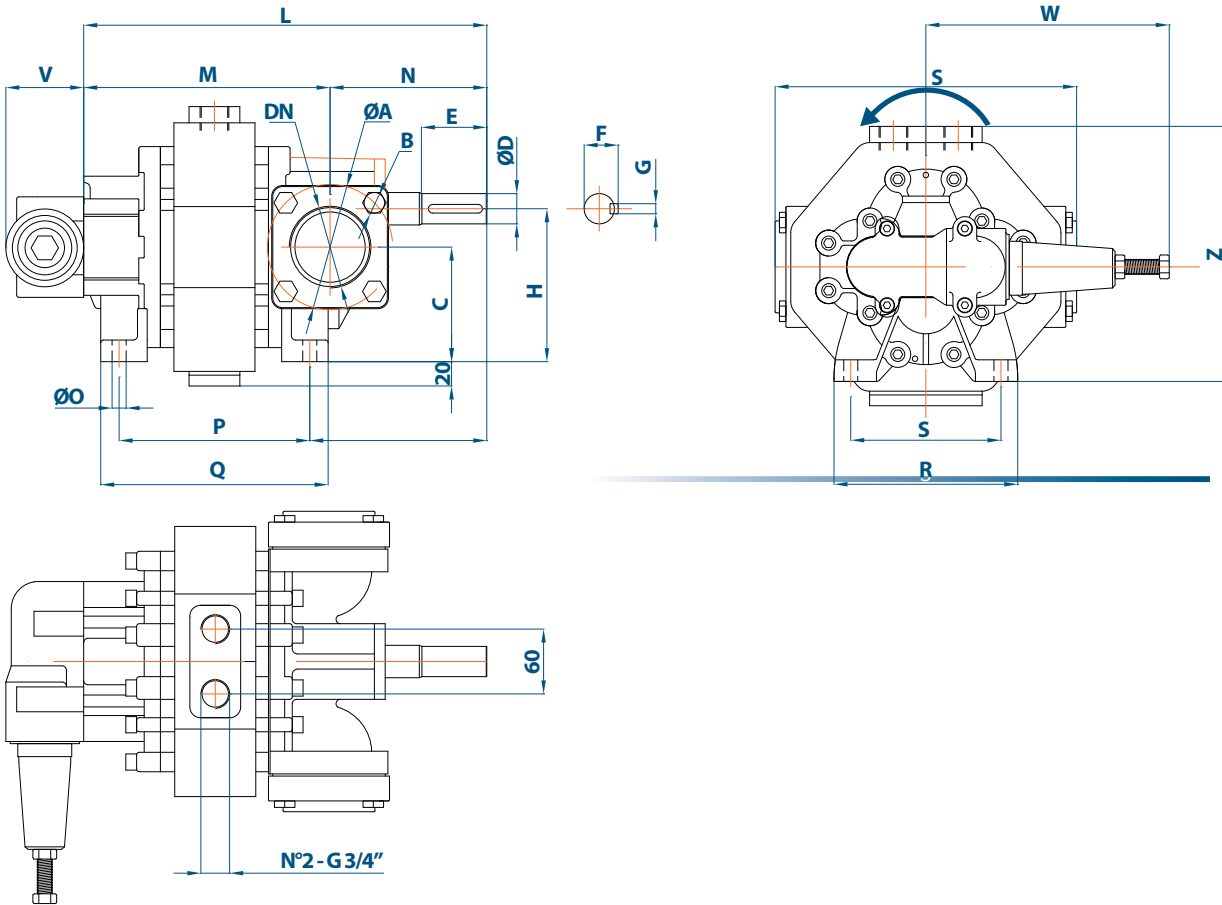

Tab. 517 - BC200 to BC400 overall dimensions and weights

PUMP SIZE (BC)	DN ISO 228-1	A	B	C	D	E	F	G	H	I	L	M	N	O	P	Q	R	S	U	V	W	Z	Weight [kg]
		200	G 2"1/2	115	N°4-M12	106	28	60	31	8	142	168	323	178	145	13	118	151	139	171	210	71	
250	G 2"1/2	115	N°4-M12	106	28	60	31	8	142	168	335	190	145	13	130	163	139	171	210	71	210	200	33
300	G 2"1/2	115	N°4-M12	106	28	60	31	8	142	168	347	202	145	13	142	175	139	171	210	71	210	200	35
350	G 2"1/2	115	N°4-M12	106	28	60	31	8	142	168	359	214	145	13	154	187	139	171	210	71	210	200	36
400	G 2"1/2	115	N°4-M12	106	28	60	31	8	142	168	373	228	145	13	168	201	139	171	210	71	210	200	38

Dimensions in mm; tolerances allowed.

5.13.3 MBM, MBMC

Fig. 516 - MBM5-40, MBMC10-25 dimensional drawing

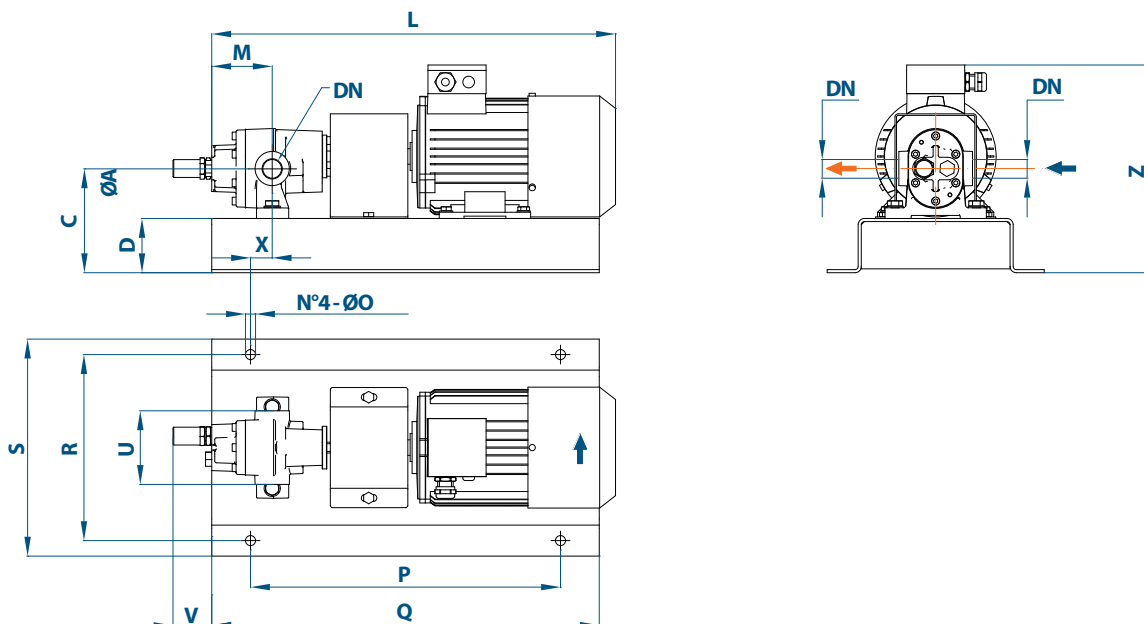

Tab. 518 - MBM5 to MBM40, MBMC10 to MBMC25 overall dimensions and weights

PUMP SIZE (MBM) (MBMC)		with IEC electric motor		DN ISO 228-1	C	D	L (*)	M	O	P	Q	R	S	U	V	X	Z (*)	Weight [kg]
		Frame size	IM															
5		71	B3	G 1/2"	134	70	423	64	13	300	400	240	280	90	50	14	261	16
		80	B3	G 1/2"	134	70	484	64	13	400	500	240	280	90	50	14	270	23
		90	B3	G 1/2"	144	70	534	64	13	400	500	240	280	90	50	14	308	33
10	10	71	B3	G 1/2"	134	70	433	74	13	300	400	240	280	90	50	24	261	16
		80	B3	G 1/2"	134	70	494	74	13	400	500	240	280	90	50	24	270	23
		90	B3	G 1/2"	144	70	544	74	13	400	500	240	280	90	50	24	308	33
15	15	71	B3	G 3/4"	134	70	443.5	68	13	300	400	240	280	95	50	18	261	17
		80	B3	G 3/4"	134	70	504.5	68	13	400	500	240	280	95	50	18	270	23
		90	B3	G 3/4"	144	70	554.5	68	13	400	500	240	280	95	50	18	308	33
25	25	80	B3	G 3/4"	134	70	514.5	78	13	400	500	240	280	95	50	28	270	24
		90	B3	G 3/4"	144	70	564.5	78	13	400	500	240	280	95	50	28	308	34
40		80	B3	G 1"	146	70	554.5	83	13	400	500	240	280	121	50	33	286	26
		90	B3	G 1"	146	70	604.5	83	13	500	600	290	330	121	50	33	314	36
		100	B3	G 1"	150	70	667.5	83	13	500	600	290	330	121	50	33	327	50

Dimensions in mm; tolerances allowed; (*) = depends on the motor manufacturer

Fig. 517 - MBM50-70, MBMC50-70 dimensional drawing

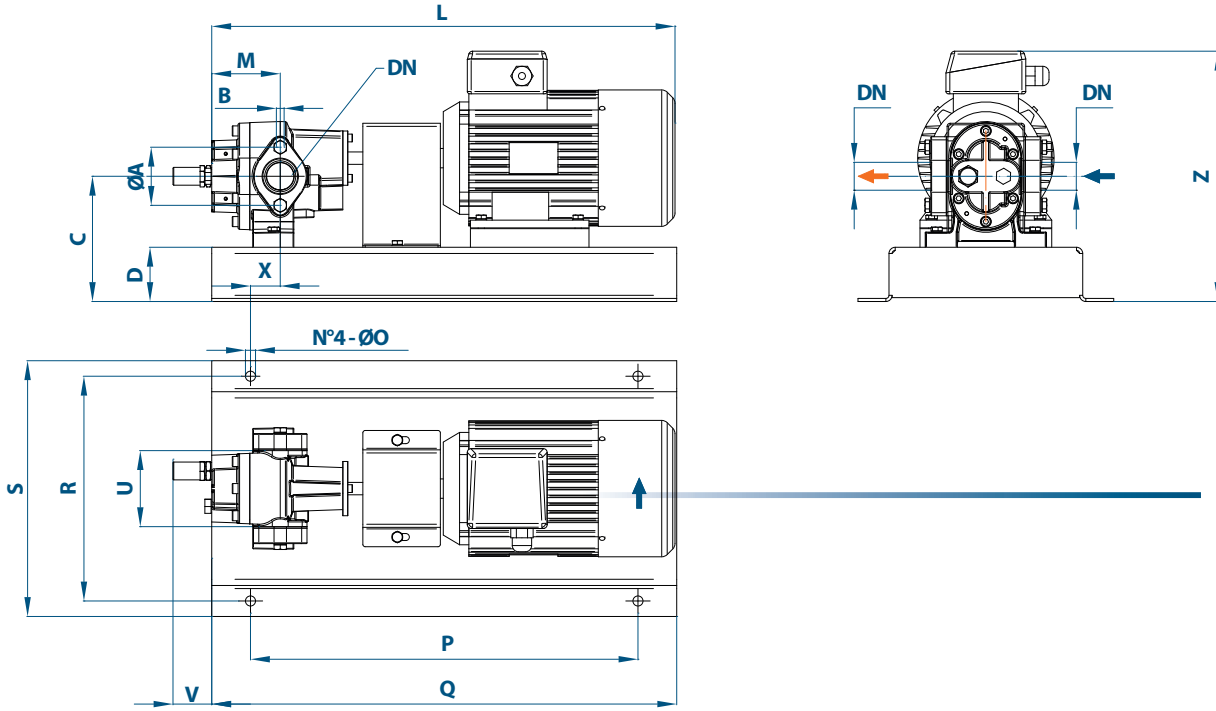

Tab. 519 - MBM50 to MBM70, MBMC50 to MBMC70 overall dimensions and weights

PUMP SIZE		with IEC electric motor		DN ISO 228-1	A	B	C	D	L (*)	M	O	P	Q	R	S	U	V	X	Z (*)	Weight [kg]
(MBM)	(MBMC)	Frame size	IM																	
50	50	90	B3	G1"1/2	75	N°2-M10	161.5	70	608	87	13	500	600	290	330	98	50	37	332	39
		100	B3	G1"1/2	75	N°2-M10	161.5	70	671	87	13	500	600	290	330	98	50	37	341	52
		112	B3	G1"1/2	75	N°2-M10	161.5	70	679	87	13	500	600	290	330	98	50	37	352	65
70	70	90	B3	G1"1/2	75	N°2-M10	161.5	70	618	90	13	500	600	290	330	98	50	40	332	40
		100	B3	G1"1/2	75	N°2-M10	161.5	70	681	90	13	500	600	290	330	98	50	40	341	53
		112	B3	G1"1/2	75	N°2-M10	161.5	70	689	90	13	500	600	290	330	98	50	40	352	65
		132	B3	G1"1/2	75	N°2-M10	179.5	70	778	90	13	550	650	340	380	98	50	40	399	97

Dimensions in mm; tolerances allowed; (*) = depends on the motor manufacturer

Fig. 518 - MBM100-150, MBMC100-150 dimensional drawing

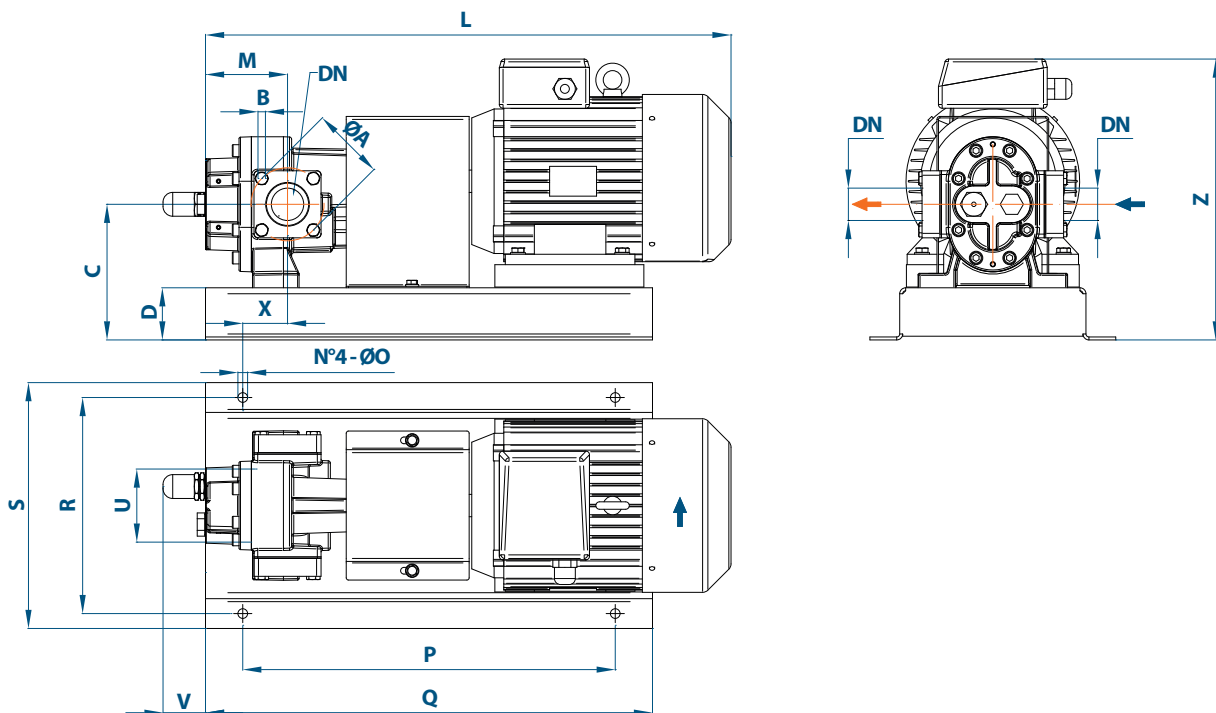

Tab. 520 - MBM100 to MBM150, MBMC100 to MBMC150 overall dimensions and weights

PUMP SIZE		with IEC electric motor		DN ISO 228-1	A	B	C	D	L (*)	M	O	P	Q	R	S	U	V	X	Z (*)	Weight [kg]
(MBM)	(MBMC)	Frame size	IM																	
100	100	90	B3	G 2"	98	N°4-M10	181	70	640.5	110	13	500	600	290	330	142	57	60	361	51
		100	B3	G 2"	98	N°4-M10	181	70	703.5	110	13	500	600	290	330	142	57	60	370	64
		112	B3	G 2"	98	N°4-M10	181	70	711.5	110	13	550	650	340	380	142	57	60	381	76
		132	B3	G 2"	98	N°4-M10	181	70	800.5	110	13	550	650	340	380	142	57	60	410	108
150	150	100	B3	G 2"	98	N°4-M10	181	70	723.5	130	13	500	600	290	330	142	57	80	370	66
		112	B3	G 2"	98	N°4-M10	181	70	731.5	130	13	550	650	340	380	142	57	80	381	79
		132	B3	G 2"	98	N°4-M10	181	70	820.5	130	13	700	800	400	440	142	57	80	410	110

Dimensions in mm; tolerances allowed; (*) = depends on the motor manufacturer

Fig. 519 - MBM200-600, MBMC200-400 dimensional drawing

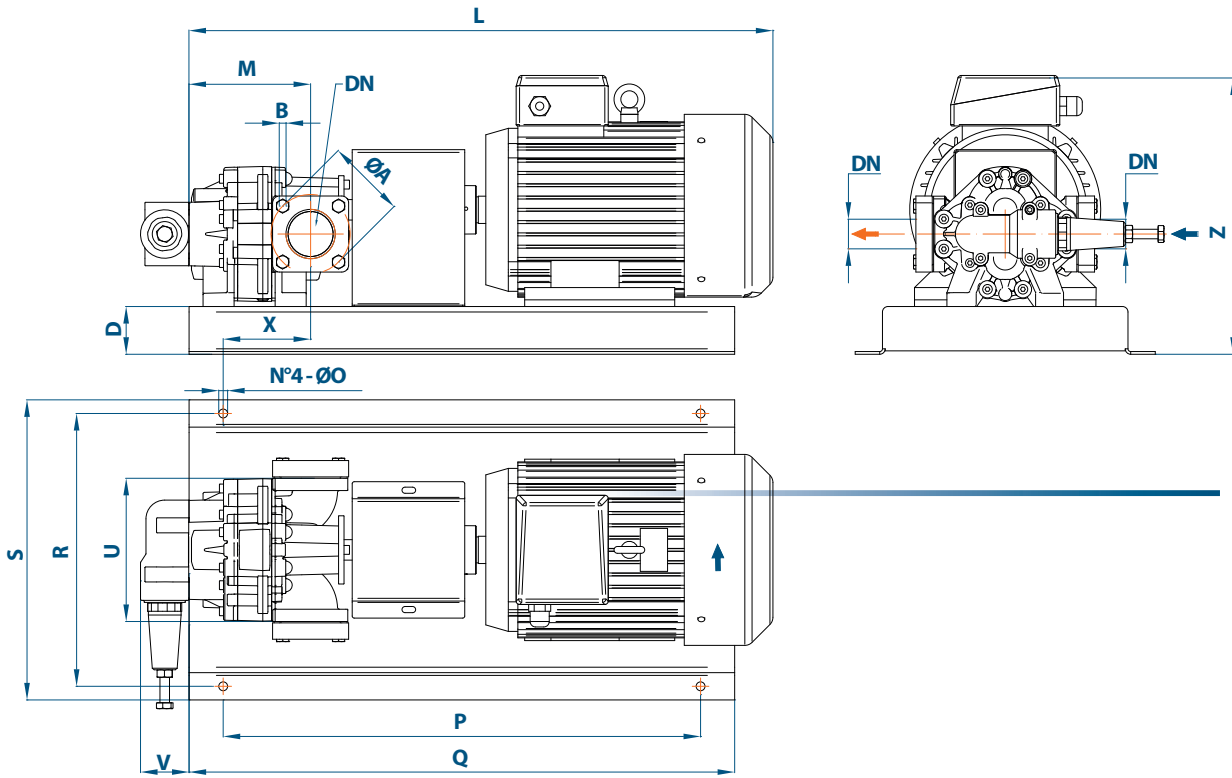

Tab. 521 – MBM200 to MBM600, MBMC200 to MBMC400 overall dimensions and weights

PUMP SIZE		with IEC electric motor		DN ISO 228-1	A	B	C	D	L (*)	M	O	P	Q	R	S	U	V	X	Z (*)	Weight [kg]
(MBM)	(MBMC)	Frame size	IM																	
200	200	112	B3	G 2"1/2	115	N°4-M12	176	70	766	178	13	700	800	400	440	210	71	128	380	86
		132	B3	G 2"1/2	115	N°4-M12	176	70	855	178	13	700	800	400	440	210	71	128	409	118
		160	B3	G 2"1/2	115	N°4-M12	194	70	990	178	13	900	1000	400	440	210	71	128	453	209
250	250	112	B3	G 2"1/2	115	N°4-M12	176	70	778	190	13	700	800	400	440	210	71	140	380	88
		132	B3	G 2"1/2	115	N°4-M12	176	70	867	190	13	700	800	400	440	210	71	140	409	119
		160	B3	G 2"1/2	115	N°4-M12	194	70	1002	190	13	900	1000	400	440	210	71	140	453	211
300	300	132	B3	G 2"1/2	115	N°4-M12	176	70	879	202	13	700	800	400	440	210	71	152	409	121
		160	B3	G 2"1/2	115	N°4-M12	194	70	1014	202	13	900	1000	400	440	210	71	152	453	213
350	350	132	B3	G 2"1/2	115	N°4-M12	176	70	891	214	13	700	800	400	440	210	71	164	409	122
		160	B3	G 2"1/2	115	N°4-M12	194	70	1026	214	13	900	1000	400	440	210	71	164	453	214
400	400	132	B3	G 2"1/2	115	N°4-M12	176	70	905	228	13	700	800	400	440	210	71	178	409	124
		160	B3	G 2"1/2	115	N°4-M12	194	70	1040	228	13	900	1000	400	440	210	71	178	453	216
		180	B3	G 2"1/2	115	N°4-M12	214	70	1122	228	13	900	1000	400	440	210	71	178	484	263
500		132	B3	G 3"	127	N°4-M12	209.5	70	914	234	13	700	800	400	440	263	102	184	454	146
		160	B3	G 3"	127	N°4-M12	209.5	70	1049	234	13	900	1000	400	440	263	102	184	480	238
		180	B3	G 3"	127	N°4-M12	209.5	70	1131	234	13	900	1000	400	440	263	102	184	491	285
550		160	B3	G 3"	127	N°4-M12	209.5	70	1058	243	13	900	1000	400	440	263	102	193	480	239
		180	B3	G 3"	127	N°4-M12	209.5	70	1140	243	13	900	1000	400	440	263	102	193	491	286
600		160	B3	G 3"	127	N°4-M12	209.5	70	1067	252	13	900	1000	400	440	263	102	202	480	241
		180	B3	G 3"	127	N°4-M12	209.5	70	1149	252	13	900	1000	400	440	263	102	202	491	288

Dimensions in mm; tolerances allowed; (*) = depends on the motor manufacturer

Fig. 520 - MBM1200-1600 dimensional drawing

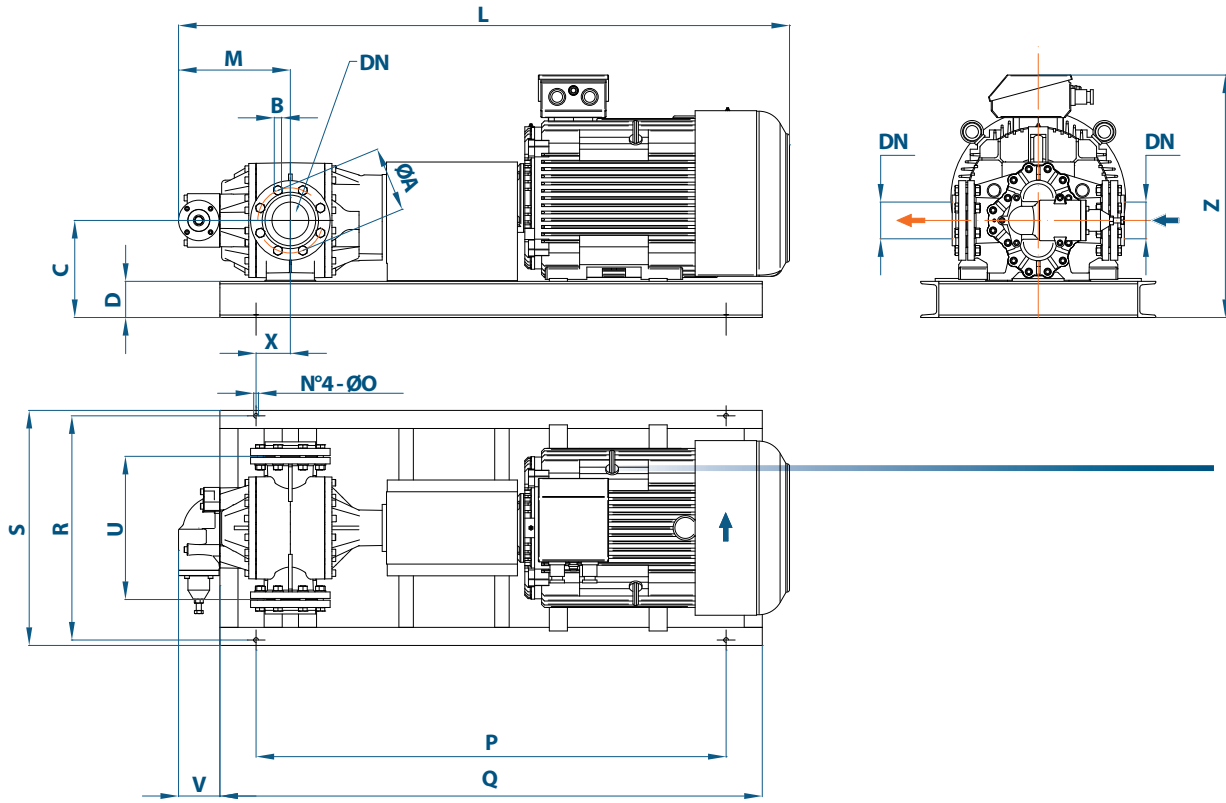

Tab. 522 - MBM1200 to MBM1600 overall dimensions and weights

PUMP SIZE (MBM)	with IEC electric motor		DN	A	B	C	D	L (*)	M	O	P	Q	R	S	U	V	X	Z (*)	Weight [kg]
	Frame size	IM	UNI 2254																
1200	225	B3	G 4"	180	N°8-M16	235.5	70	1525	234	13	1400	1500	620	650	396	114	184	643	608
1600	225	B3	G 4"	180	N°8-M16	235.5	70	1575	243	13	1400	1500	620	650	396	114	193	643	633

Dimensions in mm; tolerances allowed; (*) = depend on the motor maker.

5.14 SPARE PARTS

Fig. 521 - B3-40; BC10-25

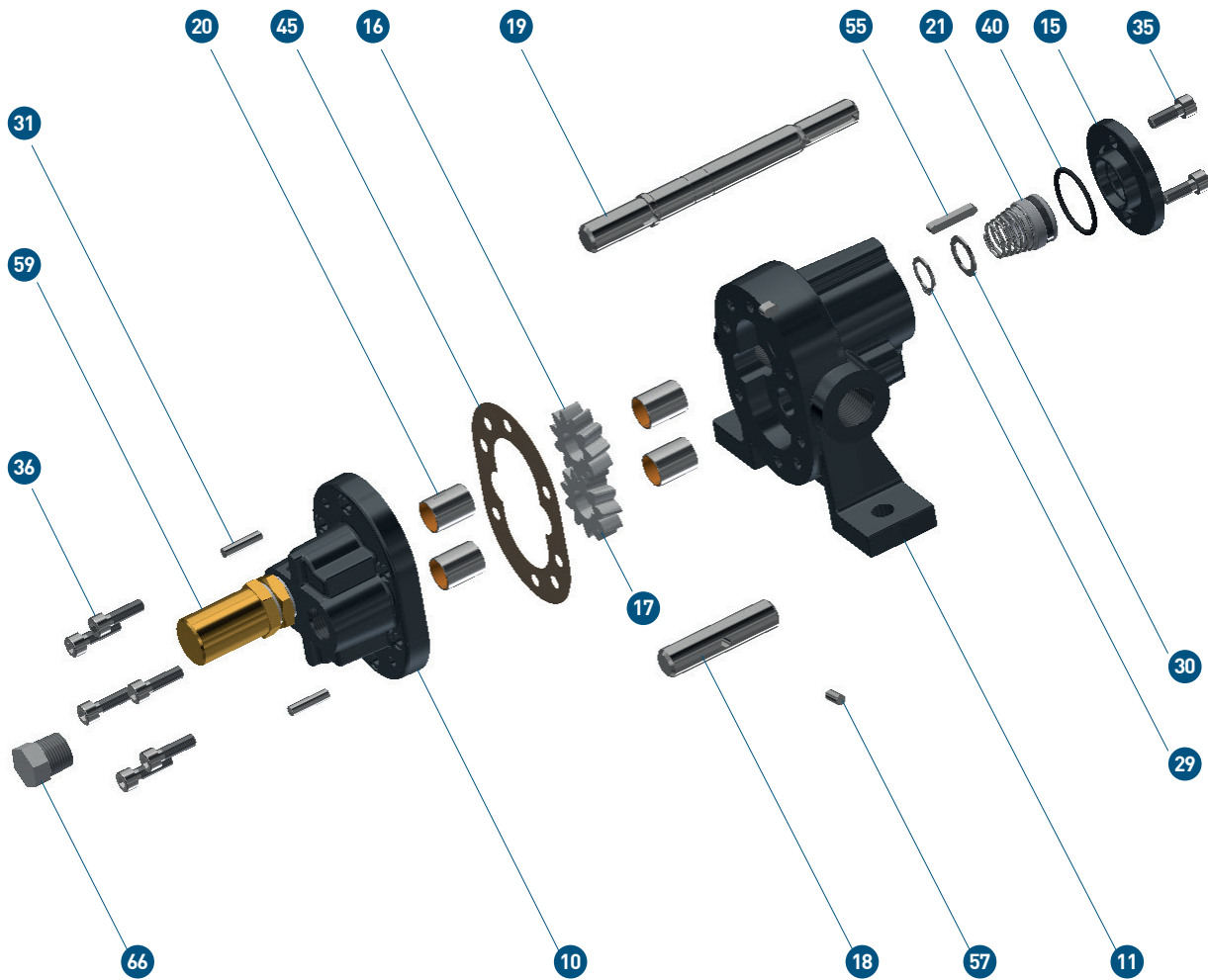

Fig. 308 - Pressure relief valve details

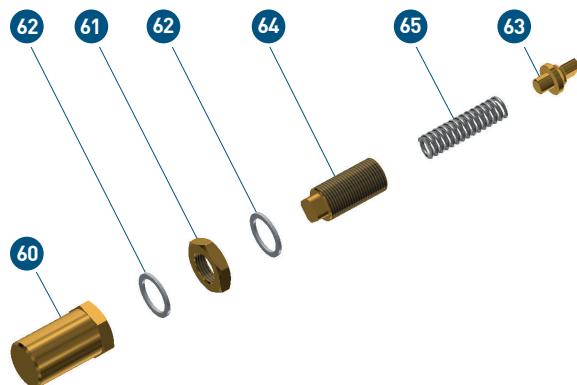

Fig. 522 - Packing seal details

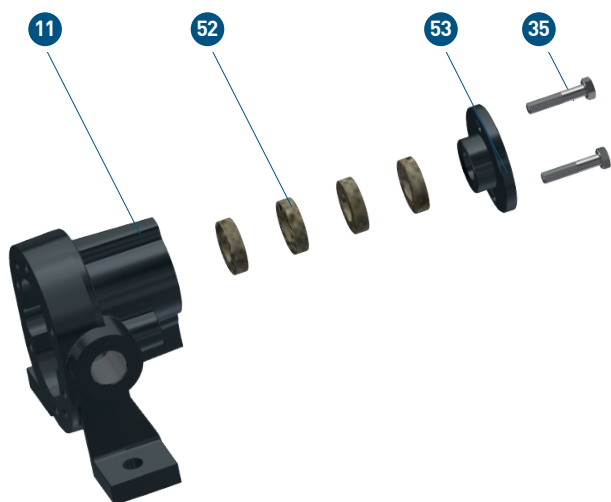
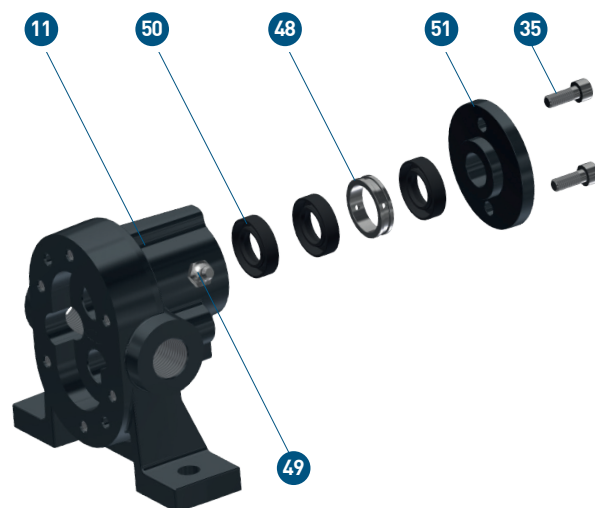

Fig. 523 - Lip seal details



Tab. 523 - B3-40, BC10-25 spare parts list

Ref.	Description	Ref.	Description	Ref.	Description	Ref.	Description
10	Pump rear cover	21	Mechanical seal	48	Lantern ring	59	Kit valve
11	Pump housing	29	Locking ring	49	Greaser	60	Valve cap
15	Mechanical seal housing	30	Ring seal	50	Lip seals	61	Valve locknut
16	Driving gear	31	Dowel pin	51	Lip seal housing	62	Valve washer
17	Driven gear	35	Screw	52	Packing	63	Valve poppet
18	Driven shaft	36	Screw	53	Packing seal housing	64	Valve adjusting screw
19	Driving shaft	40	O-ring	55	Feather key	65	Valve spring
20	Sleeve bushings	45	Cover flat gasket	57	Feather key	66	Threaded cap

Fig. 524 - B50-150; BC50-150

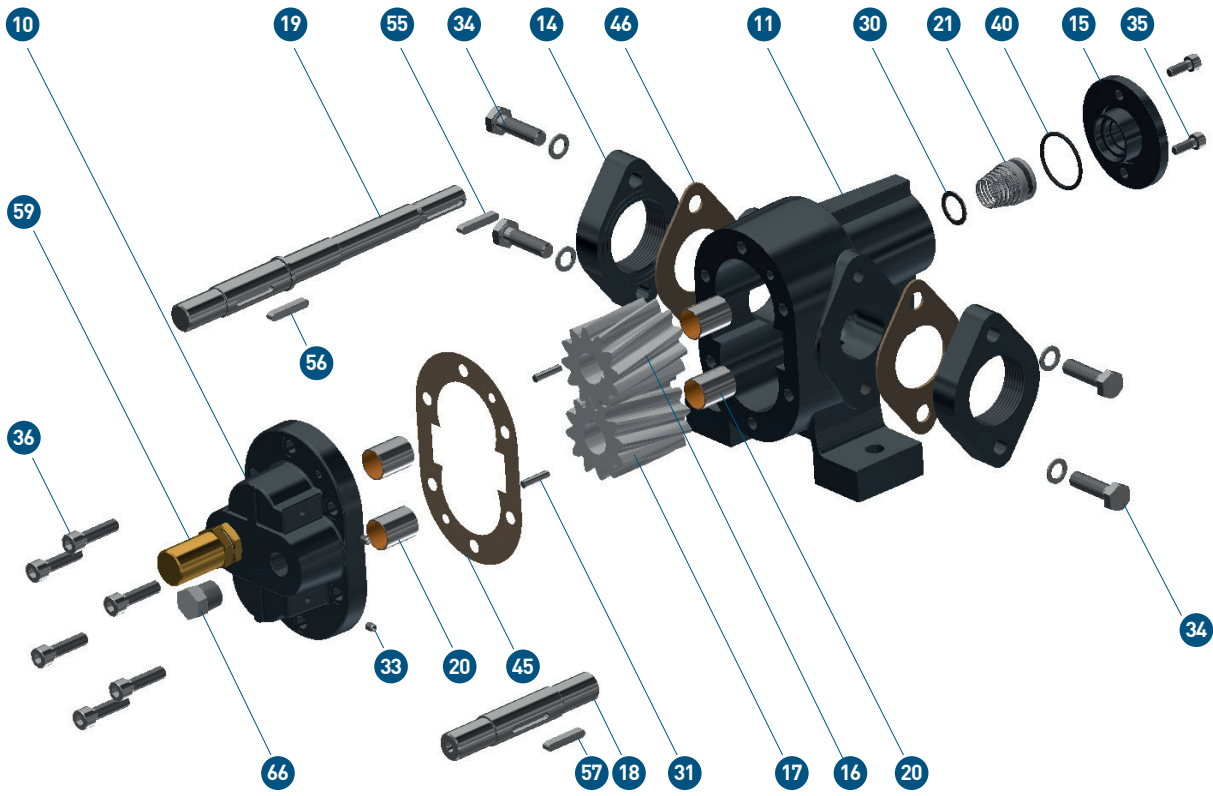

Fig. 308 - Pressure relief valve details

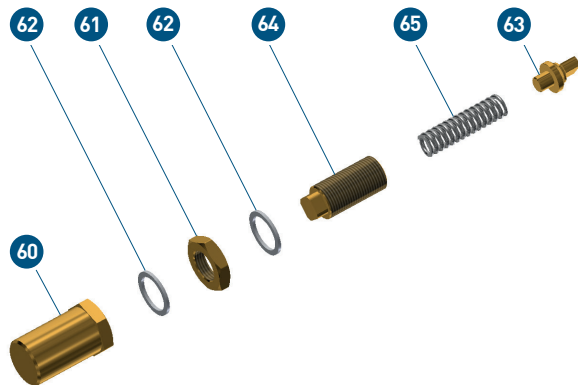
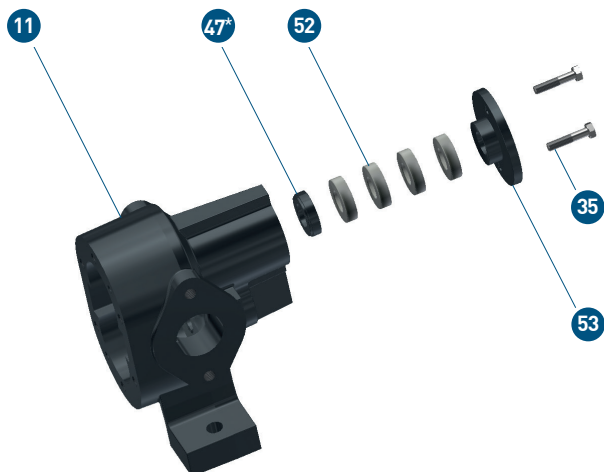
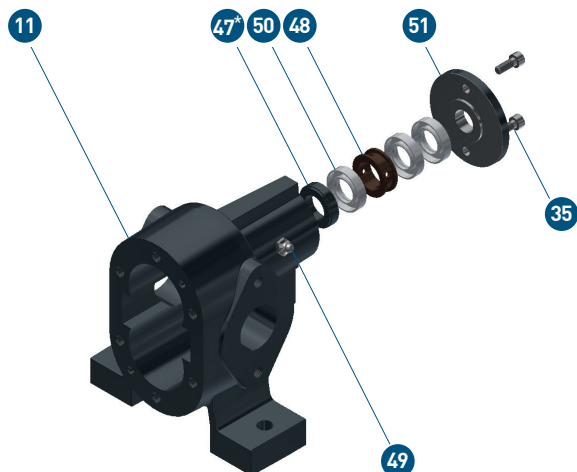

Fig. 525 – Packing seal details



(*) Only on size B50 -B70

Fig. 526 – Lip seal details



(*) Only on size B50-B70

Tab. 524 - B50-150, BC50-150 spare parts list

Ref.	Description	Ref.	Description	Ref.	Description	Ref.	Description
10	Pump rear cover	30	Ring seal	48	Lantern ring	60	Valve cap
11	Pump housing	31	Dowel pin	49	Greaser	61	Valve locknut
14	Flange	33	Grub screw	50	Lip seals	62	Valve washer
15	Mechanical seal housing	34	Bolt	51	Lip seal housing	63	Valve poppet
16	Driving gear	35	Screw	52	Packing	64	Valve adjusting screw
17	Driven gear	36	Screw	53	Packing seal housing	65	Valve spring
18	Driven shaft	40	O-ring	55	Feather key	66	Threaded cap
19	Driving shaft	45	Cover flat gasket	56	Feather key		
20	Sleeve bushings	46	Flange flat gasket	57	Feather key		
21	Mechanical seal	47*	Seal bottom ring	59	Kit valve		

(*) Only on size B50-B70

Fig. 527 - B200-600; BC200-400

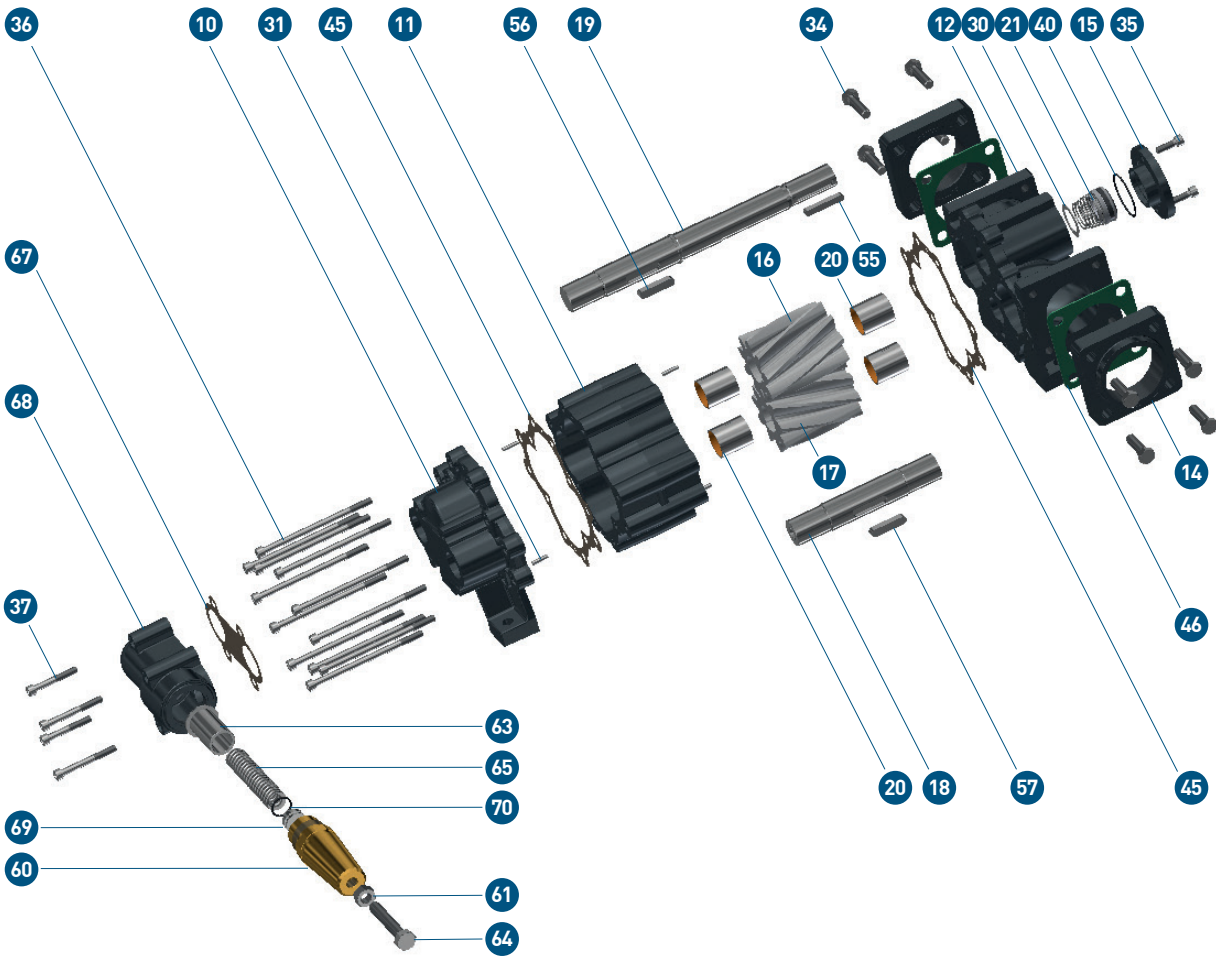

Fig. 528 - Packing seal details

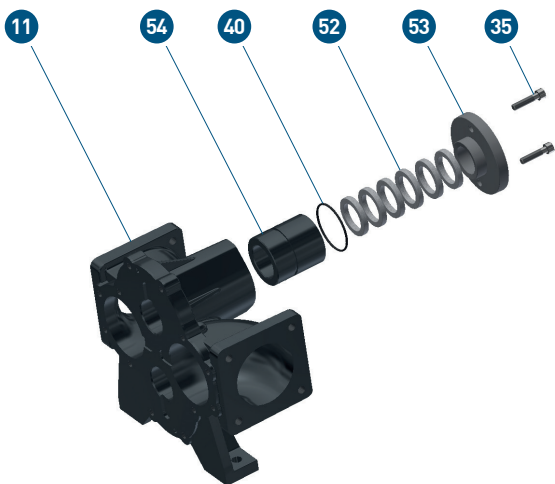

Fig. 529 - Lip seal details

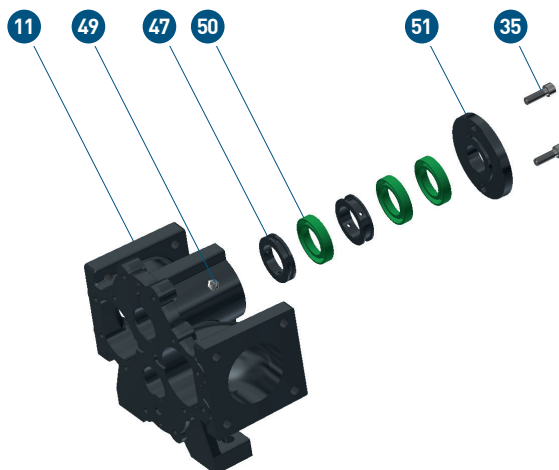
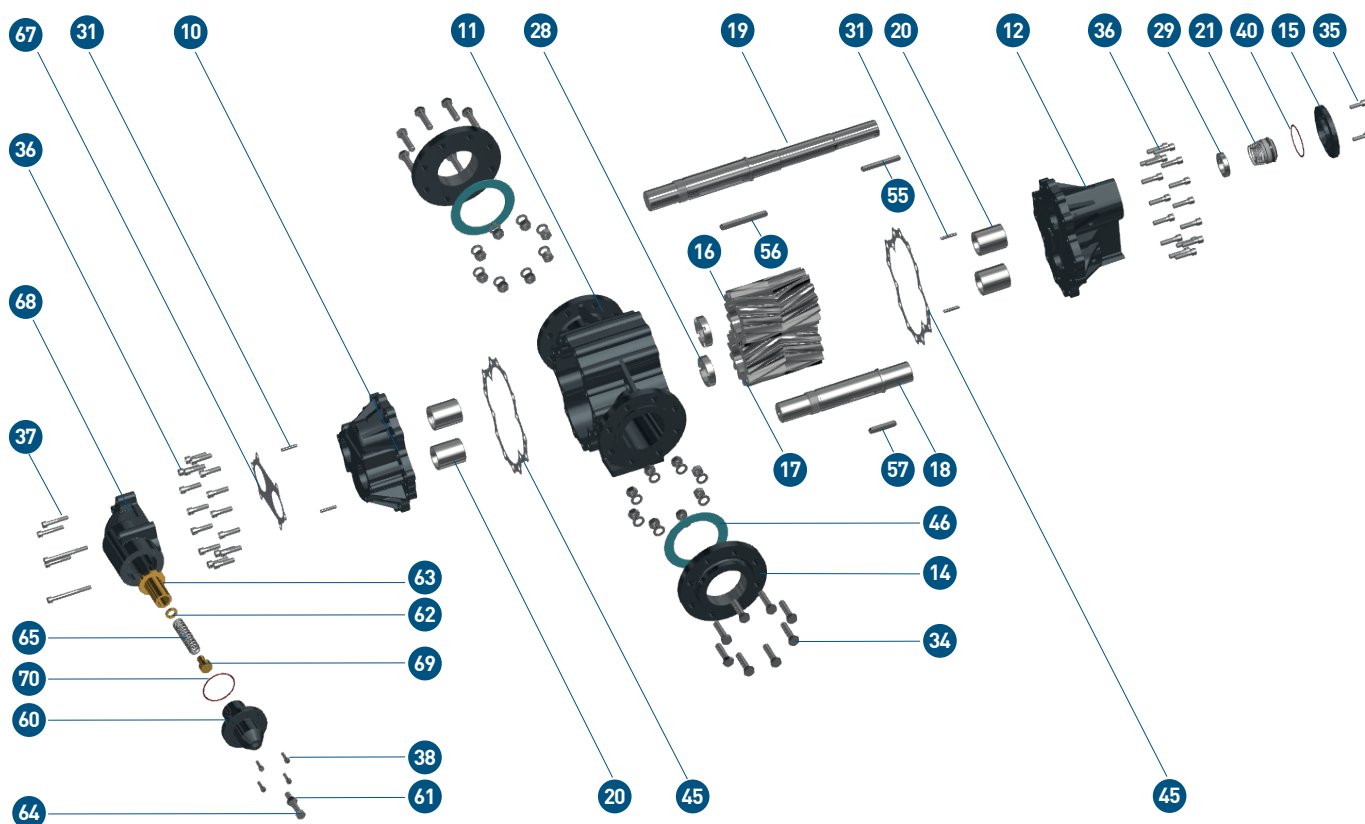

Fig. 530 - B1200-1600



Tab. 525 - B200-1600, BC200-400 spare parts list

Ref.	Description	Ref.	Description	Ref.	Description	Ref.	Description
10	Pump rear cover	28	Ring nut	46	Flange flat gasket	60	Valve cap
11	Pump housing	29	Locking ring	47	Seal bottom ring	61	Valve locknut
12	Pump front cover	30	Ring seal	49	Greaser	62	Valve washer
14	Flange	31	Dowel pin	50	Lip seals	63	Valve poppet
15	Mechanical seal housing	34	Bolt	51	Lip seal housing	64	Valve adjusting screw
16	Driving gear	35	Screw	52	Packing	65	Valve spring
17	Driven gear	36	Screw	53	Packing seal housing	67	Flat gasket
18	Driven shaft	37	Screw	54	Packing seal case	68	Valve housing
19	Driving shaft	38	Screw	55	Feather key	69	Spring cap
20	Sleeve bushings	40	O-ring	56	Feather key	70	O-ring
21	Mechanical seal	45	Cover flat gasket	57	Feather key		

Fig. 531 – MBM-MBMC

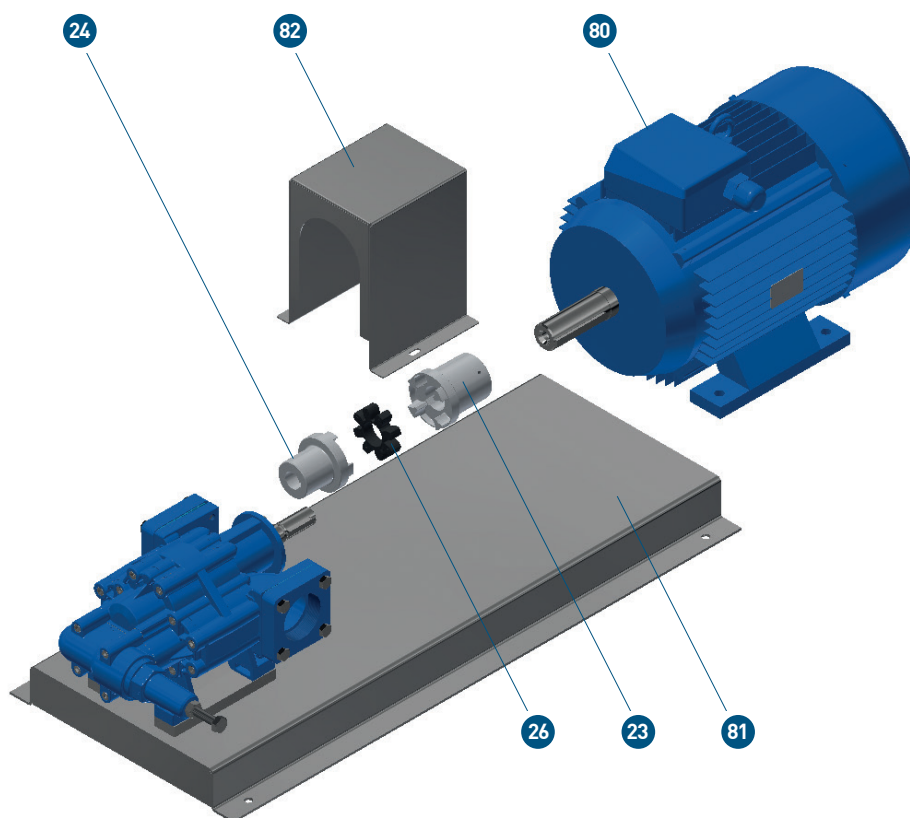

Tab. 526 - MBM, MBMC spare parts list

Ref.	Description
23	Half-coupling motor side
24	Half-coupling pump side
26	Spider
80	Electric motor
81	Skid
82	Coupling protection

GVR POMPE SRL

Via dell'Artigianato, 19
20072 Fizzonasco di pieve Emanuele (MI)
Italy

Tel. +39-02-90725577
Tel. +39-02-90725662

www.gvrpompe.com

